

COIL
WINDING

GEO. STEVENS
MANUFACTURING CO., INC.

COIL WINDING

A Description of Coil Winding Procedures,
Winding Machines and Associated Equipment.

Text, Charts, and Illustrations by

WM. QUERFURTH

First Edition

Published by

GEO. STEVENS MFG. CO.
CHICAGO — ILLINOIS

COIL WINDING

Copyright 1954 by the
GEO. STEVENS MFG. CO., INC.
CHICAGO, ILLINOIS

All rights reserved. No part of this book may be reproduced without permission in writing by the publisher.

Neither the author nor publisher assume any responsibility for the illegal or unauthorized use of patented machines or devices or other protected procedures, methods of production or descriptions contained in this book. All users are cautioned to secure proper written authorization from the parties involved for such use.

The purchase of this book does not include any right or authorization to make, copy, reproduce or sell any apparatus described herein.

PRINTED IN THE UNITED STATES
OF AMERICA

Printed by CARL GORR PRINTING COMPANY

FOREWORD

Winding machinery, like all of man's mechanization, has been made to meet a need that existed — seldom has the machine preceded its product. Accordingly, over our years of specialization in the manufacture of winding machines, we have designed and built machines to meet the changes in coil conception.

Careful observation shows that, during the past 10 years, no basically new coil shapes have been developed. The art seems to have stabilized to a point where present technique will stand for some time, therefore this book, our first effort to publish a manual or handbook devoted solely to coil winding, will fill a long realized need.

It is my sincere hope that this book will help expand the art through a better understanding of machine mechanics as well as utilization.

March, 1954

Les Stevens

PREFACE

Whereas most radio components are of standardized design and are consequently produced in large quantities with the aid of semi or fully automatic machinery, coils have always been custom made and custom designed, and their manufacturing process has always been dominated by manual operations. The decision of the engineer who plans to use a coil is often dependent upon other inherent characteristics found in a coil, instead of its inductive value alone. Certain undesirable characteristics can sometimes be reduced while still maintaining the desired inductance of the coil, by changing coil size, configuration, winding tension or wire size, to name the most common variables.

As a result of this, a wide variety of coils are constantly in demand and a specialized industry of coil manufacturers must daily face the problem of producing the many different types in sufficient quantity and uniformity. It is obvious that only a flexible coil winding industry will meet these requirements. Further, it can easily be understood that the flexibility of the coil winding industry is almost entirely dependent upon the design and features of its winding machinery. Consequently each machine should allow the greatest possible variety of coils to be wound. Furthermore, it should permit speedy changeover from one product to another. Keeping setup and tooling cost at a minimum is necessary in order to permit economical production of small coil quantities. In addition to these features, the machine must wind accurately and efficiently. Therefore, the construction, application, range, proper setup and maintenance of coil winding equipment as well as the mechanical considerations necessary for a good coil design are the main objectives of this publication.

The technician and setup-man will welcome the many suggestions that are offered, and they will save much time in solving coil winding problems. For the engineer and designer this volume presents modern coil winding theory, current practice, time saving alignment charts and gear tables.

To Mr. George Stevens, a recognized pioneer in the field of coil winding since 1927, goes sincere gratitude for his efforts in making this publication possible. Appreciation and sincere thanks must also be given to Dr. A. W. Simon, not only in recognition of his well known fundamental work on the theory of various types of windings, but particularly for his kindness in checking and analysing the geometrical subjects treated in this publication.

A bibliography of presently known previously written design information is included at the rear of the book for reference.

Wm. Querfurth

March 2, 1954

CONTENTS

Page

Introduction	x1
--------------------	----

CHAPTER 1

SINGLE LAYER WINDINGS

1. Rack Driven Machines	1
2. Cam Driven Machines	6
3. Linear and Variable Pitch Cams	9
4. Progression Gear Box on Standard Bench Models	13
5. The Progressive Universal Machine.....	14
6. The Resistor Strip Winding Machine	15
7. Wire Guides, Wire Tensions and Tension Devices	16
8. Speed Regulation	20
9. Semi-Automatic Machines	20
10. Counters	22
11. Arbor and Chuck Design	24

CHAPTER 2

MULTI LAYER WINDINGS

1. Cam Driven Machines	29
2. The Screw Traverse Machine	30
3. Hand Winding Machines	33
4. Heavy Wire Winding	34
5. Miniature Winding	36
6. Textile Interwinding	37
7. Multiple Paper Section Winding	38

CHAPTER 3

THE UNIVERSAL TYPE WINDING

1. Construction	43
2. Gears and Cams	45
3. Gear Box Setup	47
4. Wire Guide Adjustment	49
5. Guide Pressure	50
6. Disc Windings and Flyback Coils	52
7. The Behaviour of Various Wire Insulations	53

	Page
8. Winding Speed and Production Setup	54
9. Pi-Windings	57
10. The Design of a Step Cam	60
11. The Winding of IF-Transformers	63
12. Universal Bifilar	66
13. Honeycomb Windings	66
14. Oscillator Coils and C-Windings	67
15. Self Resonant Coils	67
16. Geometry	68
17. Surface and Wall Patterns	72
18. The Practice of Gear Ratio and Gear Selection	76

CHAPTER 4

THE PROGRESSIVE UNIVERSAL WINDING

1. The Construction of the Progressive Universal Winding	79
2. The Progressive Universal Winding Machine	80
3. Geometry of the Winding	81
4. Winding Patterns	83
5. The Practice of Calculating the Gear Ratio	84
6. Variable Pitch Progressive Universal Winding	85

BIBLIOGRAPHY

APPENDIX

INDEX

INTRODUCTION

The book is divided into four chapters, each covering a basic type of winding. These four winding types are illustrated in Fig. 1.

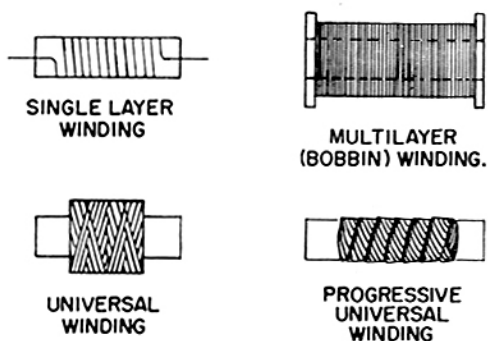

FIGURE 1—Four basic types of windings.

Because high winding speeds are common, certain precautions are necessary to insure uniform results. For instance, the very fine diameter wires often used (as fine as .002 inch) have extremely thin insulating films (.0001 inch) that must not be damaged during winding. Damage of the insulation may cause shorted turns lowering the inductance and "Q" of the coil, or damaged insulation may cause premature voltage break-down in certain applications.

In order to maintain close electrical tolerances, mechanically stable windings must be produced. This is a very important consideration where large volume production is undertaken. Without repetitive uniformity, excessive losses may occur in addition to added inspection costs. Controlled windings are the result of sound coil design. A very important part of the coil designer's work is the selection of the all important gear trains, or gear ratios, that will produce electrically stable, mechanically sound coils.

All moving parts of a coil winding machine have a definite relationship to each other. These relationships are precise and must be maintained to guarantee uniformity of product. The most accurate and simple method of maintaining the exact relationships required is through the use of gears. Because the related motions may vary with respect to each other, as different coil configurations require, interchangeable gears must be employed

to provide the required ratios between various parts of the winding machine.

Gears further provide a positive method of reproducing any ratio previously used to wind coils. This is invaluable in coil duplication whenever re-runs are required. The reproduction of a previously wound coil at any time becomes a simple matter of gear change, and where required, a cam change.

In general, a winding machine closely resembles a lathe. As Fig. 2 illustrates, it consists of a headstock (1), and a tailstock (2), both mounted to a bed (3), a guide mechanism and an electric motor (4). In addition a winding machine usually has a turns counter (5), and employs suitable means to unreel the wire.

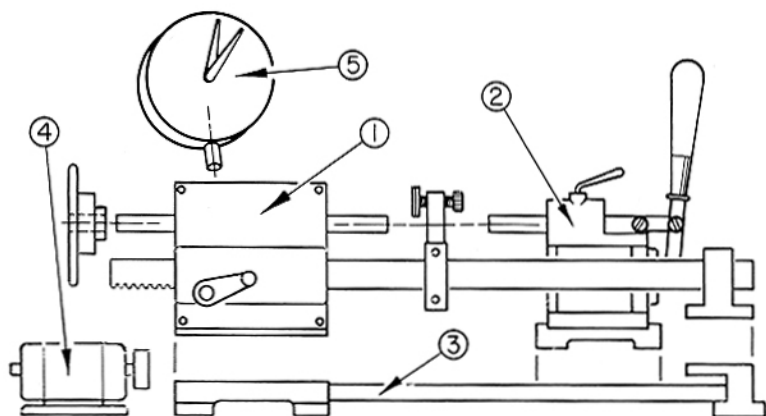

FIGURE 2—Basic parts of a winding machine.

Often, machines are built as bench models to allow them to be inserted in production lines wherever necessary.

Machines of this type are available from Geo. Stevens Mfg. Co., and the procedures outlined in the following chapters are based on their very popular designs.

CHAPTER 1

SINGLE LAYER WINDINGS

1. **RACK DRIVEN MACHINES.** The most common method of winding a single layer coil or solenoid employs a machine with a revolving main shaft and a progressing wire guide. The function of the wire guide is to place the wire on to the coil form at a predetermined location. In the case of a close wound single layer coil, adjacent turns will touch each other, while in the case of a space wound coil a definite and controlled space exists between adjacent turns. The direction of movement of the wire guide is parallel to the axis of the coil form, and for a close wound coil the progression of the guide will be equal to the amount of one total wire diameter per revolution of the coil form.

The wire guide is mounted to a rack which is activated by a small pinion gear whose shaft is coupled to the main shaft by a set of gears.

Thus the movement of the wire guide is directly related to the revolution of the main shaft and its relation can be expressed as a ratio of the number of teeth of the driven gear z_n (mounted on the pinion shaft) to the number of teeth of the driver gear z_r (fixed to the main shaft). This ratio will be referred to as the gear ratio throughout the entire book and will be identified by the letter r in all calculations. For example:

$$r = \frac{z_n}{z_r}$$

The mechanism of a rack driven winding machine is shown in Fig. 3, where (1), is the main shaft driven by a motor (2). On the work end of the main shaft a winding chuck, used to hold the coil form, is shown, see (3). A worm drive turns the driver shaft (4). The transmission between the main shaft and the driver shaft has a convenient ratio of 100 : 1. The driver shaft and pinion shaft (5) can be linked with any combination of gears ranging from:

- 25 teeth, minimum size to
- 100 teeth*, maximum size for the driver shaft
and from
- 60 teeth*, minimum size to
- 120 teeth, maximum size for the pinion shaft.

(*recommended limit)

thus enabling 4,640 different gear combinations to fit into the gear box. The range of the gear ratios reaches from:

$$\frac{120}{25} = 4.80 = r_{max.}$$

to

$$\frac{60}{100} = 0.60 = r_{min.}$$

The driven gear and the driver gear are linked by an idler gear which does not alter the gear ratio. The idler gear can be any size. A compound set of idler gears, employing various size gears mounted on a common axis, can be used to multiply the main gear ratio by the amount which these idler gears yield if their numbers of teeth are written as a ratio.

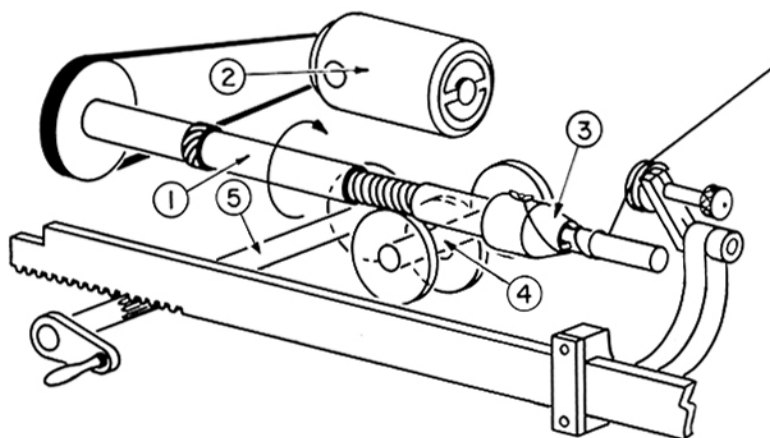

FIGURE 3—Mechanism of a rack driven machine.

Three different types of idler gear assemblies are shown in Fig. 4. Fig. 4-A shows a straight idler gear (2), linking the driver gear (1), and the driven gear (3). The gear ratio is determined only by the gears (3), and (1).

Fig. 4-B shows a compound idler set (4). Its purpose is to reverse the direction in which the guide moves in respect to the direction in which the coil form turns. It has no effect upon the gear ratio.

Regardless of the size (number of teeth) of the described idler gears in Fig. 4-A and 4-B, the gear ratio is determined only by the driven gear and the driver gear.

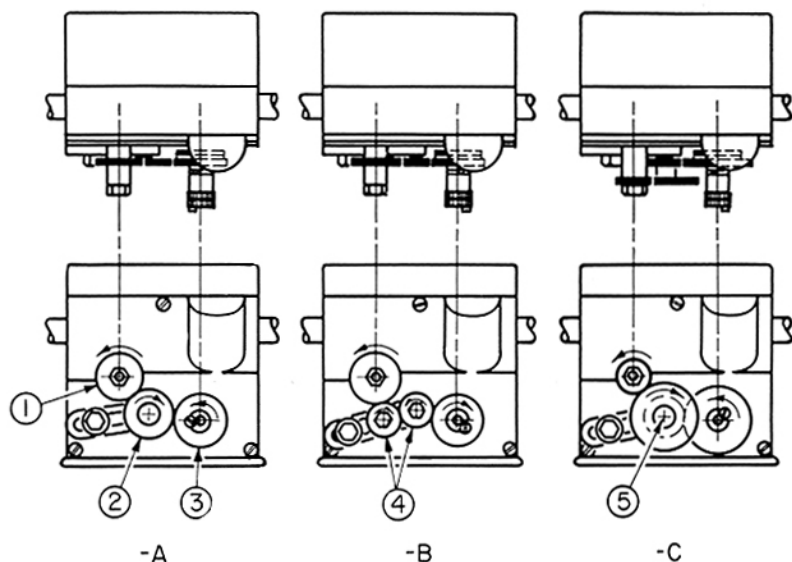

FIGURE 4—Idler gears.

Fig. 4-C shows a set of idler gears, both gears being of different size but mounted on a common shaft (5). The larger idler gear in this example meshes with the driver gear and the smaller idler gear meshes with the driven gear. In expression, they are identified as follows:

Driver Gear	= z_r
Idler Gear meshing Driver Gear.....	= z_x
Driven Gear	= z_n
Idler Gear meshing Driven Gear.....	= z_y

The resultant gear ratio expression is

$$r = \frac{z_x \times z_n}{z_y \times z_r}$$

Compound gear sets are classified according to their own ratios. Some popular idler gear ratios are

$$\begin{aligned} 80 / 40 &= 2 : 1 \\ 90 / 30 &= 3 : 1 \\ 120 / 30 &= 4 : 1 \\ 40 / 80 &= 1 : 2 \\ 30 / 75 &= 1 : 2.5 \end{aligned}$$

When these popular idler gear combinations are coupled with various driver and driven gears, the total number of gear ratios possible will increase to more than 20,000 and the range available will be from

$$r = \frac{120}{25} \times \frac{120}{30} = 19.2 \quad (\text{or } 1,830 \text{ tpi})$$

to

$$r = \frac{60}{100} \times \frac{40}{80} = 0.30 \quad (\text{or } 28.6 \text{ tpi}^*)$$

(tpi = turns per inch)

For example, the model 130 space winding machine manufactured by the Geo. Stevens Mfg. Co. uses 48 pitch diameter gears. The pinion and the gear rack are also hobbled to a 48 pitch diameter. As a result, the total travel of the rack with each pinion turn is equal to 1.0472 inch.**

The driver gear is coupled to the main shaft through a step down ratio of 100 : 1. Thus, 100 revolutions of the main shaft will cause the driver shaft to make one revolution. If a gear set having a ratio of $r = 1$ is mounted into the gear box, using a straight idler to mesh both the driver and driven gears, the resulting travel of the rack will be 1.0472 inch for 100 main shaft revolutions.

For one main shaft revolution, the rack travel will be equal to 0.010472 inch and the winding factor will be 95.49 tpi, which represents the so-called inherent pitch of the winding machine, identified by the letter P .

Using P , the inherent pitch of the winding machine, as a factor and t , the number of turns per inch, it is possible to determine r , the ratio of the number of teeth of the driven gear divided by the driver gear, as follows:

$$r = \frac{t}{P}$$

$$P = 95.49$$

* By increasing the driver gear to 125 teeth and decreasing the driven gear to 39 teeth it is possible to wind 15 tpi. At 15 tpi, the machine should be run slowly because of the fast traverse speed of the rack.

**A standard pinion gear has 16 teeth. A gear and rack having 48 pitch diameter will result in $48/16 = 3$; $\pi/3 = 1.0471976$. The inherent pitch therefore is $100 \times 3 : \pi = 95.493$.

If we know the number of turns per layer desired, which we shall designate by T and the displacement of the cam which we shall label c , and if we know the wire size δ which represents the total wire diameter including the insulation, the relation is

$$\begin{aligned} t &= I/\delta \\ T &= c/\delta \\ t &= T/c \\ T &= t \times c \end{aligned}$$

A summary of all gear ratio formulae is given in the appendix.

Space wound single layer coils or resistors can be wound on the Geo. Stevens model 130 if the desired pitch falls within the range of 15 to 1,830 tpi. Using a 32 pitch rack and pinion on a machine similar to the one described also changes the progression of the rack per pinion turn. This change provides a different max. to min. ratio. The model 135, featuring a 32 pitch diameter rack and pinion, will produce a 3.15 inch rack travel, or progression, for each revolution of the pinion, which results in a progress of 0.0315 inch per main shaft turn or 31.83 tpi if a $r = 1$ gear ratio is used.

The total range of this type machine will therefore be somewhat extended so far as spacing the wire is concerned. Further details can be taken from latest catalogues.

When calculating gear ratios for space wound coils, the wire diameter δ should be increased by the amount of space desired between adjacent turns. For close wound coils, only the value of δ should be entered in the formula. The total wire diameter δ can best be determined by winding a close wound single layer coil of one hundred turns by hand, measuring the total length of the winding, converting into decimals of an inch and then dividing the value by 100.

The two described types of rack driven machines are limited to single layer windings. Usually the wire is wound from left to right. In order to return the wire guide and rack to the starting point after a winding has been completed, the pinion shaft is coupled to the driven gear by a simple clutch whose friction is large enough to move the rack, and still is not so large as to prevent the rack and guide from being returned to its starting point. The rack is returned manually using a crank conveniently located at the front of the machine.

The model 135, featuring a larger progression, uses a positive clutch instead of the friction clutch. A separate lever has to be activated when disengaging the pinion from the driven gear.

Turns counters, wire guides, tailstocks, tension devices, speed regulation and general maintenance are the same as on other bench mounting models and a description of these parts and subjects is given elsewhere.

The procedure for proper selection of gears, once the gear ratio r has been determined, is given in Chapter 3, Section 18 of this book.

2. *CAM DRIVEN MACHINES.* The advantage of the cam driven machine compared to the previously described rack driven machine lies in its ability to wind more than one layer of wire and in its special feature of winding coils having a variable pitch. Fig. 5 shows two single layer, space wound coils. The coil shown at the left has a uniform spacing between turns, while the one shown at the right has an increasing space between turns or a variable pitch.

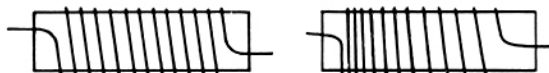

FIGURE 5—Single layer, space wound coils.

The mechanical details of a cam driven machine are illustrated in Fig. 6. This machine* employs a cam driven traverse bar to carry the wire guide. In Fig. 6 the main shaft (1) is motor driven (2) and has a collet at the work end to hold the coil form (3). The driver gear mounting shaft (4) is powered from the main shaft through the 100 : 1 worm and worm gear as illustrated. The driven gear shaft (5) is used to rotate the traverse cam (6) which moves the traverse rack (7) and wire guide (8) according to the cam shape and rotation. The gear ratios available between the cam gear (driven) and the driver gear range from

$$r_{min.} = 0.30$$

to

$$r_{max.} = 19.2,$$

where r is the ratio of the number of teeth of the cam gear to the driver gear.

The gear box located in the rear of the machine is of standard design and uniform for all bench models. It is therefore the same as the previously described gear box. For further details refer to

*Geo. Stevens Mfg. Co. model 118

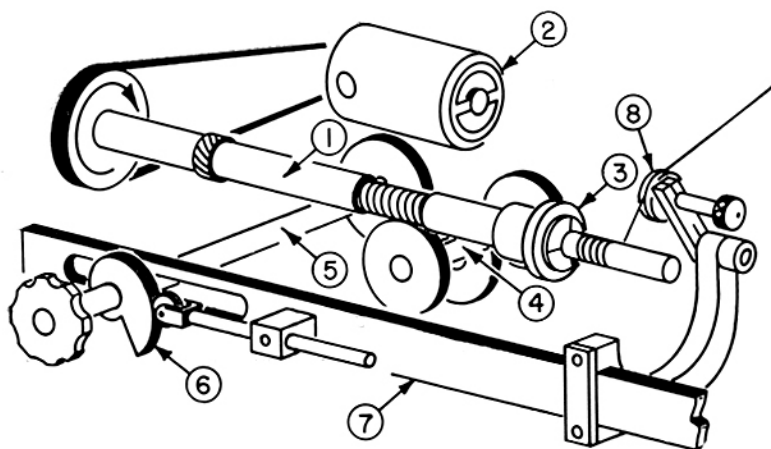

FIGURE 6—Mechanism of a cam driven machine.

the section labeled "Progression Gear Box on Standard Bench Models."

Two basic types of cams can be used on this type machine. They are the linear and non-linear types. The linear cam can be the common heart-shaped cam having a constant rise per degree for 180° revolution from the cam minima to maxima, and a constant rate of fall from the cam maxima to minima. If revolved a full 360° this cam will cause the traverse bar to move from the starting point to an extreme in one direction, reverse direction of traverse and travel to the other extreme of the total displacement returning to the starting point. Thus, such a cam can be used for winding two layers per cam revolution. If a linear cam of the heart shaped variety is revolved only 180° , only one layer will be wound.

Non-linear cams are used to produce a varying rate of travel of the traverse bar with respect to the main shaft's revolution. Variable pitch single layer coils are commonly produced utilizing this principle. Linear as well as variable pitch cams are discussed in greater detail in the section on "Linear and Variable Pitch Cams."

A single layer winding, featuring a linear pitch, is usually wound with a 360° cam whose total displacement is at least equal to, and preferably somewhat larger than the length of the coil or solenoid winding.

One revolution of the cam shaft will cause the traverse bar and associated wire guide to travel a distance equal to the displacement of the cam. A 100 : 1 ratio between the main shaft and the driven shaft will cause the traverse bar to move an amount equal to the cam displacement in 100 main shaft revolutions.

Compared to the rack driven machines, the inherent pitch of the cam and machine combined will be equal to

$$P = \frac{100}{c}$$

where c represents the cam size in inches. To find the gear ratio r for a given number of turns per inch t , use the previously derived formula

$$r = \frac{t}{P}$$

and substitute for P the value $100/c$.

Therefore

$$r = \frac{tc}{100}$$

If the coil is to be wound with a 180° cam (heart shape), the travel of the traverse bar in any one direction will be completed at exactly one-half revolution of the cam shaft. Thus

$$r = \frac{tc}{50}$$

Finally, the number of turns per inch t can be determined as follows:

$$t = \frac{1.000}{\delta}$$

where δ is the total wire diameter or the sum of the total wire diameter plus the desired spacing between adjacent wires.

In the case of a varying winding pitch or of a multiple layer coil, the expression "turns per layer" is used. A varying pitch coil makes the use of a specially designed cam a necessity. (See "Linear and Variable Pitch Cams"). The cam is designed for one layer of

a certain length. As given previously, the relation between turns per inch and turns per layer is as follows:

$$\begin{aligned}t &= 1.000/\delta \\T &= c/\delta \\t &= T/c \\T &= t \times c\end{aligned}$$

where T is the number of turns per layer. However, care must be exercised when a special cam is designed for other than 360° cam rotation. Determining the gear ratio r for a cam rotation other than 360° or 180° , closely follows the previous derivation and is

$$r = \frac{T \times 360 : \alpha}{100} \quad \text{for a } \alpha \text{ degree cam}$$

$$\begin{aligned}\text{or } r &= T \times 3.6/\alpha \\r &= T/100 \quad \text{for a } 360^\circ \text{ cam} \\r &= T/50 \quad \text{for a } 180^\circ \text{ cam}\end{aligned}$$

Linear cams whose ratio of rise versus cam rotation is unknown, can be easily determined by installing the unknown cam and a set of equal gears ($r = 1$) in the machine. Using this setup to wind a single layer of wire exactly one inch long, while counting the number of turns wound in this length, will directly give us the inherent pitch P of the machine and cam combined. The number of turns wound is equal to P , the inherent pitch.

The previously unknown cam is now characterized and can be used to wind coils within the cam's range. Gear trains to be used in combination with this cam can be found from

$$r = \frac{t}{P}$$

or substituting for t

$$r = \frac{1}{P \times \delta}$$

3. **LINEAR AND VARIABLE PITCH CAMS.** A linear cam is characterized by its radius varying a constant amount per unit rotation.

A variable pitch cam has its true cam line represented by a non-linear function of radius versus unit rotation.

The true cam line is the line described by the center of the milling cutter when cutting the cam. It is also the line described by the center of the cam follower during the winding process.

The apparent cam line differs from the true cam line, therefore it is necessary to use a cam follower with exactly the same radius as the milling cutter (See Fig. 7). It is obvious that at points (1) and (2) the deviation of the apparent from the true cam line is great. These points are the maxima and minima of the wire excursion. Precision cams and cam followers are required for bobbin winding machines and especially universal winding machines.

Cams can be designed for any number of degrees of active rotation. Most popular cams, however, are those used with 180° or 360° of active rotation.

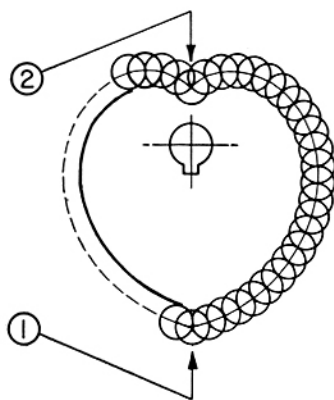

FIGURE 7—Linear 180° cam, symmetrical type.

The so-called heart-shaped cam is a 180° linear cam and has a constant diameter at any point drawn through the axis of rotation, though the radius varies continuously in a linear fashion. Fig. 7 shows the layout and the appearance of a linear 180° cam where both sections, each having 180° , are symmetrical. This type of cam is used for multilayer coils as well as universal windings.

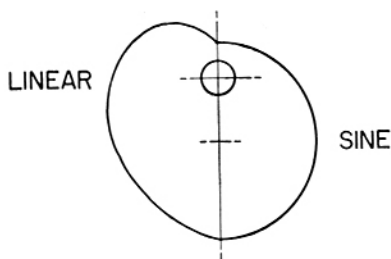

FIGURE 8—Non-symmetrical cam, 180° type.

The cam shown in Fig. 8 has one active linear 180° section while the second section follows a sine function. The purpose of the sine section is to provide a smooth return to the start position after the winding of one single layer has been completed.

For the winding of single layer coils or solenoids a 360° cam as shown in Fig. 9 is more commonly used.

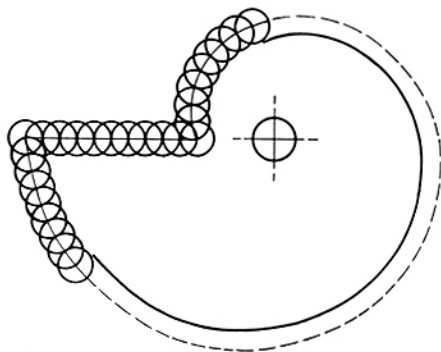

FIGURE 9— 360° cam.

Making a variable pitch cam to produce coils that require irregular spacings (such as are used for permeability tuning) can often be simplified by roughing out a preliminary cam from a brass or fiber blank and then filing the cam to correct coil shape as experimental windings are made. As the final shape is approached, minor filing may be done on the cam while it is in position on the machine. The finished cam should be used as a "master" cam, and hardened steel production cams can be copied from it on a profile milling machine.

Variable pitch cams, following certain definite geometrical functions must be laid out carefully. The desired cam line must be written in table form, detailing radii length for each degree, or portion of a degree of the cam. The greater the number of radii specified, the more accurately cams can be milled.

In some cases it appears to be advisable to rotate the cam beyond 360° in order to produce extremely long coils. Cams of this type look like a short spiral and are made to special order.

The simplest 180° non-linear cam is a sine wave cam. Its true cam line describes an exact circle. The center of rotation, however, does not coincide with the center of the circle but is placed offcenter in one direction in an amount equal to the width of the winding desired. Cams of sine wave shape were frequently used for the progressive universal winding and for single layer coils.

When setting up a bobbin winding machine*, having two cam followers and employing a heart-shaped cam, great care must be exercised to insure that the cam followers are in precise alignment. This is necessary in order that the traverse bar and the wire guide follow the exact line of the cam.

Each cam follower consists of a roller which is mounted on an adjustable rod. The center of both rollers must be in exact line with the center of the cam. The cam must be precisely cut in order to have a constant diameter through the center of its mounting hole, to any diametrically opposite point on its surface. Lastly the axes of the two rollers must be exactly parallel to the axis of the cam shaft.

These very important points in alignment are shown in Fig. 10. There we have illustrated in

10-A Line of centers *A, B, C*.

10-B Equal diameters at any line *AB, CD*, etc.

10-C Axes parallel to each other.

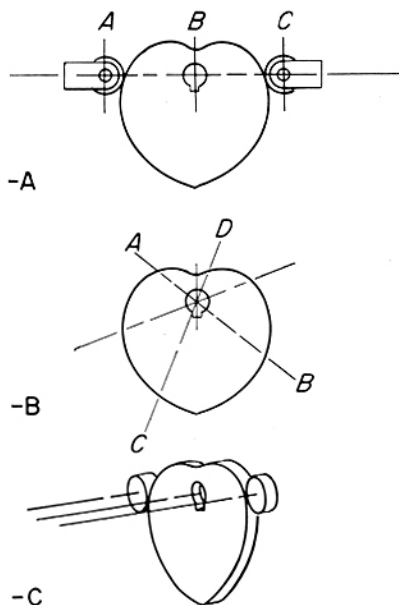

FIGURE 10—Points of alignment for two cam followers.

*Geo. Stevens Mfg. Co. model 115

4. **PROGRESSION GEAR BOX ON STANDARD BENCH MODELS.*** As Fig. 11 illustrates, the standard progression gear box houses the driver gear (1), the driven gear (2), and the idler gear with bracket (3). This design was found to be both versatile and flexible, therefore this setup is used with most bench machines.

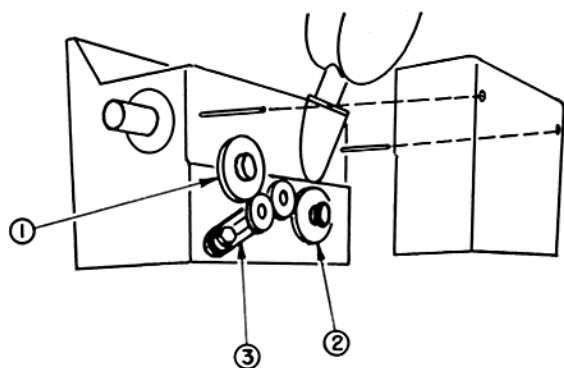

FIGURE 11—Progression gear box.

A cast iron cover is used to enclose the gear train. For lubrication, a commercially available product, known as "Lubriplate" is recommended. It is suggested that all gears and cams of the machine be lubricated periodically.

The rear wall of the standard headstock has a machined surface with a number of staggered mounting holes provided to permit proper location of the idler bracket to mesh driver and driven gears. The idler bracket has an elongated mounting slot to clear the idler mounting screw that is used to hold the idler gear assembly in place. An exploded top view, Fig. 12, shows the order of assembly used in mounting the progression gears as well as the friction clutch, all located in the progression gear box. Shown are: (1) Driver gear shaft, (2) driver gear, (3) spacer, and (4) nut. The idler consists of: (5) bracket, (6) gear assembly and, (7) mounting screw with washer (8) which holds the idler against the mounting place (9).

The friction clutch consists of: (10) Keyed driven shaft, (11) matching clutch face, (12) friction disc, (13) driven gear, (14) spacer, (15) spring washer, (16) two knurled nuts, one to tighten the clutch assembly, one used as a locking nut.

*The gear box as described here appears on Geo. Stevens Mfg. Co. models 73, 112, 115, 118, 125, 130, 131, and 225.

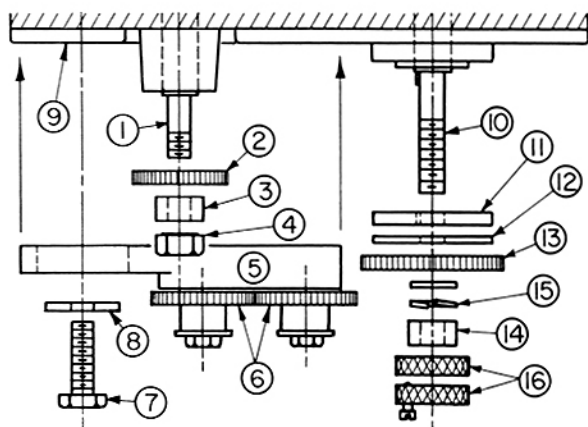

FIGURE 12—Progression gear box assembly plan.

5. *THE PROGRESSIVE UNIVERSAL MACHINE.* For a description of the original purpose of the progressive universal winding machine* refer to Section 4 of the book.

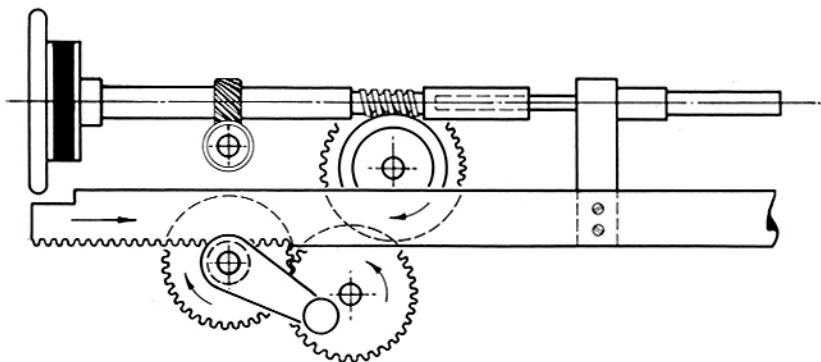

FIGURE 13—Coil progression mechanism.

The progressive universal winding machine can also be used to wind single layer coils, provided the universal shuttle mechanism is disengaged. This can be done simply by removing the front idler gear and bracket from the universal gear box, and by locking the shuttle mechanism in place. The machine, so arranged, will wind a single layer coil by moving the rotating coil form at the desired pitch, past the stationary wire guide.

*Geo. Stevens Mfg. Co. models 125 and 225

Another procedure uses a bracket with an attached wire guide mounted on the gear rack and allows the machine to be used in the same manner as the rack driven machine. All gear ratios will be the same as used for a given winding on the rack driven machine (48 pitch diameter type machine). The telescopic main shaft extension has to be removed together with its support, and the chuck or arbor must be directly attached to the main shaft.

The function of the coil progression mechanism is shown in Fig. 13. The wire guide bracket is illustrated in Fig. 14.

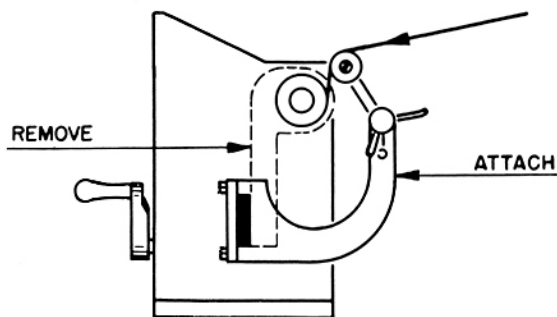

FIGURE 14—The conversion of a progressive universal winding machine in a rack driven winding machine.

6. *THE RESISTOR STRIP WINDING MACHINE.*** This type of winding machine is used for winding flat resistor strips. Basic design is similar to the progressive machine, but the strip winder has an extended length bed and rack, and as a special feature, a hollow main shaft from which the unwound strip is drawn.

The winding procedure is as follows: The unwound strip is loaded into the hollow main shaft. The main shaft itself is longer than on ordinary winding machine shaft, and at the working end a slotted guide bushing is located. The strip (cardboard, fishpaper, etc.) is pulled through the slot while the main shaft and slotted bushing turn it. The strip is held at the starting end by a live-center-chuck, the latter being connected to the progressing rack, thus pulling the strip out of the hollow main shaft while the strip turns.

The live-center-chuck can be driven in synchronization with the main shaft as an optional feature for winding very thin flexible strips.

**Geo. Stevens Mfg. Co. model 131

The wire guide and wire supply are fixed and do not move. The wire guide must be adjusted so as to apply the wire as close as possible to the bushing at the main shaft. No bending of the strip occurs during winding, and tight windings can be made through application of maximum tension to wire. Fig. 15 illustrates this type of winding machine.

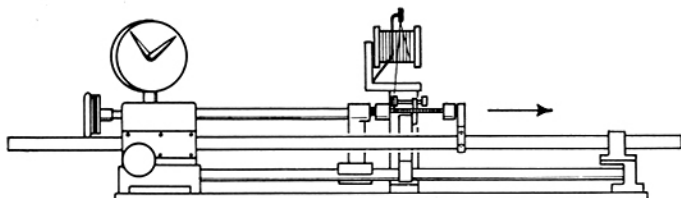

FIGURE 15—Resistor strip winding machine with stationary wire guide.

The machine is of standard design otherwise, and all requirements regarding gear ratio and amount of progression can be taken from the article on the rack driven machine.

Since modifications are possible, the rack could be moved by a cam instead of a pinion gear. Variable pitch windings can thus be made. However, the length of the wound section will be limited to the available space for the cam at the front of the machine.

7. WIRE GUIDES, WIRE TENSIONS AND TENSION DEVICES. With the exception of the resistor strip winding machine and all universal winding machines, the wire guide will be mounted on the rack or cam traverse bar of the machine. For the purpose of single layer windings simple wire guides are sufficient. A roller with a groove will usually suffice. (See Fig. 16). Two types of guide arms are illustrated.

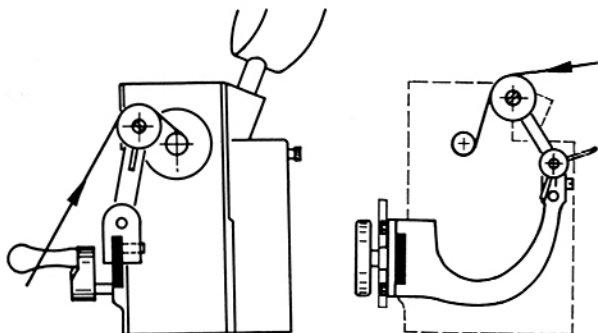

FIGURE 16—Wire guides for single- and multi-layer windings.

Usually, the wire is taken from the supply spool and cut after the coil is wound at the machine. In some cases, when only a short length of wire is required and the wire has sufficient strength, it is supplied to the machine in pre-cut lengths.

Generally, the wire supply and tension device is located behind the machine. It is more practical, however, when only a few turns are required and when the wire is heavier than #32 AWG, to locate the supply spool in front of the machine. For this purpose several types of tension and supply devices are available, some of these are illustrated in Fig. 17.

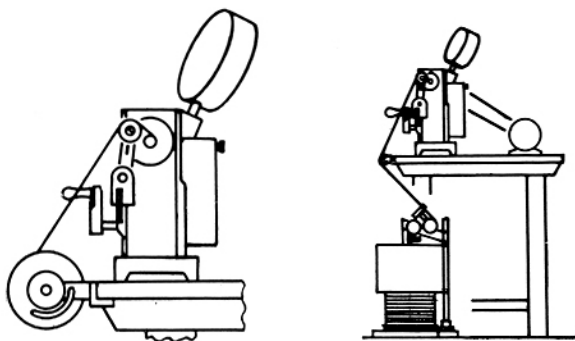

FIGURE 17—Location of wire supply devices in front of the machine.

When winding on square or rectangular forms, provision must be made to even out the pulses caused by the shape of the winding form. Small rollers, carried at the end of a spring loaded lever, will provide a compensating effect. In fine wire winding, the choice of supply and tension equipment is of greatest importance. A precaution that will pay dividends should be taken when winding universal and fine wire bobbin coils. The following is suggested:

It is advisable to measure the wire tension used when successful windings result. Relative methods are suitable, and even a simple tension-type calibrated spring scale will be of help. The wire may be pulled tightly over the coil as shown in Fig. 18. When the wire has begun to move over all rollers and levers and when the motion of the wire has caused the supply spool to rotate, the measurement should be taken. On multiple winding machines, the tension should be equal on all tension devices used on the multiple setup.

Tension measurements should be recorded for future use and should be a part of all winding specifications.

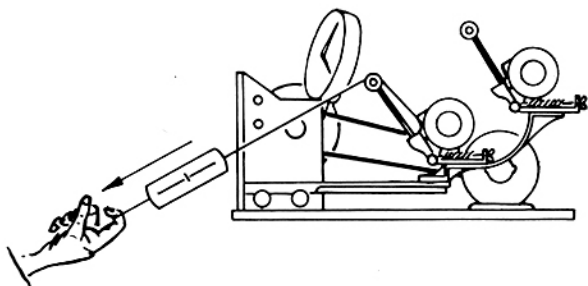

FIGURE 18—Simple method of measuring wire tension.

In general, fine wire requires less tension and heavy wire requires more tension.

Fig. 19 shows two basically different tension devices. Type A allows the wire to be removed from the spool at almost any speed. The wire supply spool remains stationary inside a protective cone. The wire is wound once or twice around the capstan whose resistance to turning is controlled by a friction brake. The brake pressure can be varied by means of an adjustable spring. However, it must be noted that one twist will be imparted to the wire for each turn taken from the supply spool. A spinner will prevent tangling and knotting of the finer wire sizes. (Fig. 20-E).

The type B tension device as illustrated in Fig. 19 is dependent on winding speed and spool weight. The supply spool turns while the wire is unreeled. The wire runs over a free turning roller, the latter being mounted at the end of a spring loaded brake lever. The brake lever causes a delayed action in releasing the spool, thus providing a constant amount of tension. The restricting and smoothing action of the brake lever on type B makes the device very desirable for universal winding.

In many respects these tension devices have properties mutually exclusive from one another. For example while type B permits easy respooling, type A excludes this feature. While type A permits rapid starts and stops encountered in automatic-controlled winding machines, type B requires more moderated winding acceleration and deceleration. The amount of tension is independent of the supply spool weight when using type A. However,

spools to be used in type A must have smooth edges, otherwise the wire might be damaged.

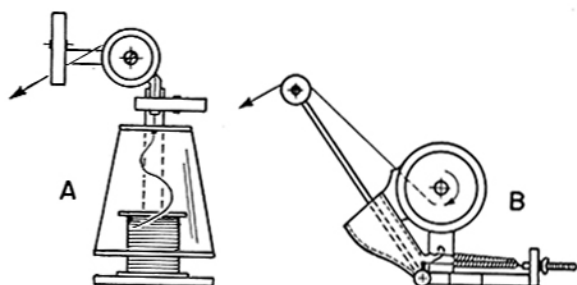

FIGURE 19—Tension devices.

A modification of the type A device in Fig. 19 is the so-called spinner as shown in Fig. 20-C. Fine wire spools having rough or damaged edges require a spinner type device, if the unreeling speed is not too high.

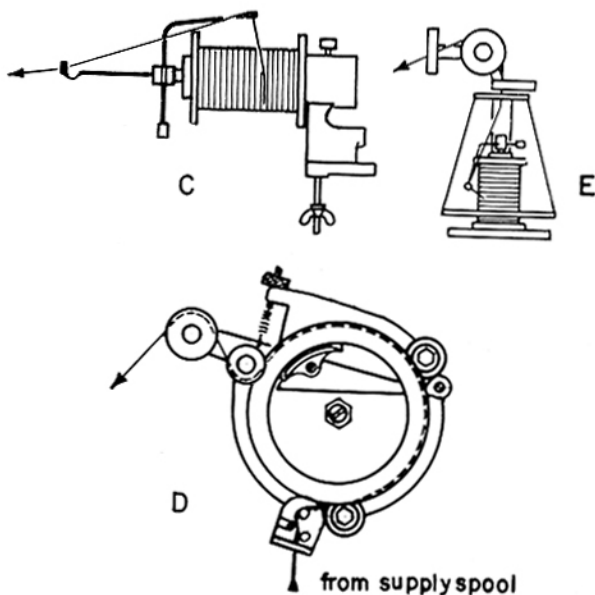

FIGURE 20—Tension devices.

Another tension head design is shown in Fig. 20-D. The spool in this case remains stationary, but a light weight tension wheel and brake drum provide a lever regulated tension to the wire.

This type is highly recommended where space is restricted, as is often the case in multiple winding. Tension control is good. This device is especially recommended where fine textile served wires are used.

8. *SPEED REGULATION.* The speed of a winding machine can be regulated by different means. If the motor used is of the series-wound type, not exceeding $\frac{1}{4}$ HP, the motor can easily be regulated with a series variable resistor. Foot controlled rheostats are popular, and variable auto transformers are also widely used.

Constant speed and continuous operation, even under varying load conditions, can be achieved by using a belt transmission between the machine and motor. Pulleys of various sizes are helpful in changing the motor to machine drive ratios. In extreme cases, especially where heavy gauge of wires are to be wound, a wormgear drive may be used. Gearhead motors with 10 : 1 ratios are commercially available.

Excessive winding speed frequently results in defective coils. Consequently, a speed limiting device should be provided. A resistor in series with the motor or a mechanical stop located under the foot lever of the foot controlled rheostat serves well. The correct belt transmission ratio between motor and winding machine is highly desirable, however, in most cases, it is too inconvenient to arrange, especially where winding setups are changed frequently. Thus the foot controlled rheostat is the primary and most easily used device for achieving various winding speeds.

Slowing and stopping a winding machine is frequently done by hand. A smooth handwheel, to which the operator's hand may be applied gradually for breaking action, is suitable.

The On-Off switch, if not foot operated, should be conveniently placed, preferably near the handwheel. For example in Fig. 21 the thumb or the last finger of the left hand can operate the switch.

9. *SEMI-AUTOMATIC MACHINES.* Time consumed in winding coils can be reduced by tooling machines with special features that eliminate or speed up manual operations. The many types of attachments, switches and fixtures that may be employed to reduce cost and improve productivity are, in most cases, limited to specific windings. Compressed air operated tooling is gaining much favor because of its simplicity and wide range of adaption.

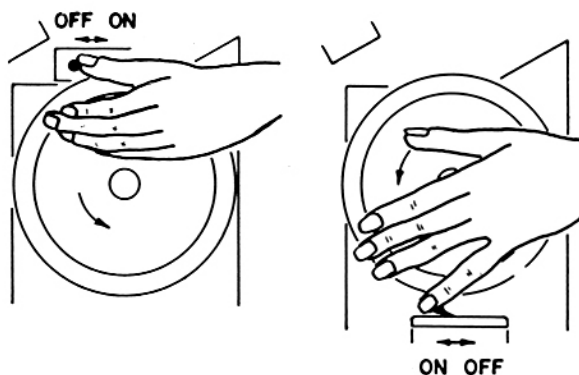

FIGURE 21—On and Off-switch location.

The predetermined counter and automatic stop is one of the most universally adopted improvements that increases operator efficiency. Not only is the total time of the winding cycle reduced, but winding can be performed at a uniform speed for each coil, thereby contributing to coil uniformity what is possibly most important. The machine operates without requiring the operator's attention, allowing minor finishing or other operations to be performed by the operator.

Two types of counters are used with the automatic stop mechanism. They are the crank-handle-reset and the quick-lever-reset predetermined type. Both are somewhat similar in their appearance and function, however, setting procedures are different. Details will be found in Section 10 of this Chapter.

An automatic counter can be used in several ways. Some of the possibilities are described below:

When the number of turns wound reaches the pre-set value, the counter switch opens, removing the motor power, and operates a brake, stopping the machine. Equipment required in addition to the predetermined counter is a magnetic brake and a small d.c. power supply.

Other semi-automatic features can be added where facilities are available. The tailstock can be operated by compressed air. Brakes and clutches can be operated with air pressure, their valves being operated by rotary switch controlled solenoids. Part of the chucking operation and the complete start lead securing and finish lead securing is usually done by hand. A spotting wax or cement convenient to the coil, is of help in securing the start and finish leads.

10. *COUNTERS.* One of the most important parts of any winding machine is the turns counter. Clock dial counters are very popular and are available as standard equipment usually provided with non-automatic winding machines. They are dependable and easy to read. Fig. 22 shows two types of dial counters each having two pointers. One pointer indicates every 100 turns, while the other pointer indicates each single turn (100 turn Dial—10,000 total*) or each $\frac{1}{4}$ turn (25 Turn Dial—2,500 total**) whichever is more suitable. The pointers are gear driven and turn continuously. A helical gear coupled to the main shaft drives the counter mechanism. Either type with its proper drive shaft can be interchanged on Stevens' winding machines.

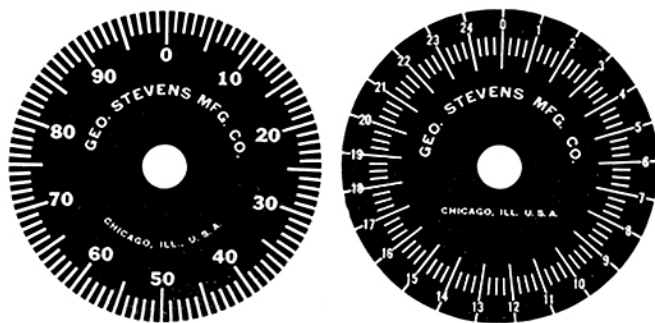

FIGURE 22—Dial counters.

Predetermined type counters, because of the advantages they provide through reducing production costs, are very popular. Chain, gear or timing belt driven, the automatic counter is coupled to the main shaft and can be made to perform certain functions. One arrangement stops the machine when the proper number of turns have been wound. In general, the automatic counter operates a switch which can be inserted in the motor circuit directly or which can operate a separate relay, or an electromagnetic clutch or brake, whichever specific requirement is best suited to the job.

Three types of automatic counters are illustrated in Fig. 23. All are suitable for use with any of the machines described.

The setting procedure is slightly different for each type of counter. The following procedures are recommended.

Series 1239 counters: With motor switch in "Off" position,

*Geo. Stevens Mfg. Co. model 50

**Geo. Stevens Mfg. Co. model 51

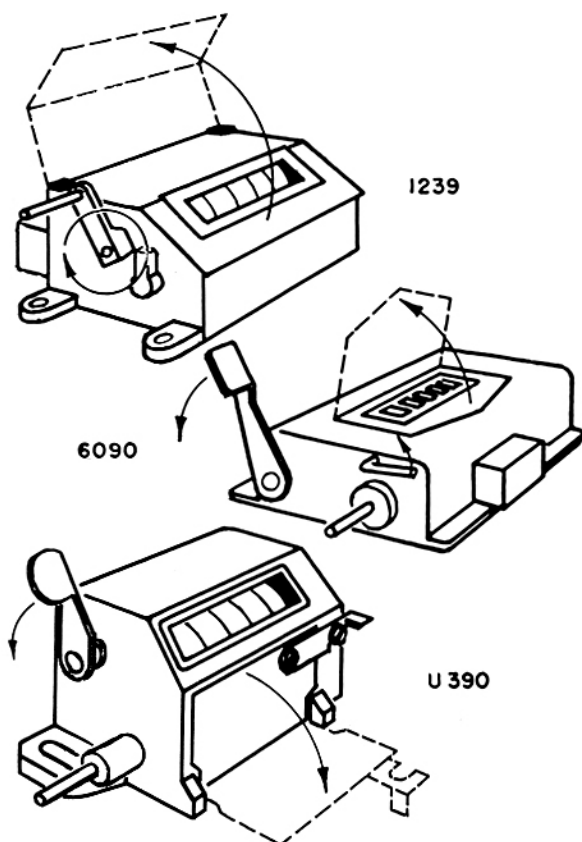

FIGURE 23—Automatic counters.

turn reset crank until all figures on the white wheels indicate zero. Lift the cover to expose all wheels. Metallic wheels should be displaced to the right using finger pressure. Rotate metallic wheel until desired figure appears opposite white wheel's zero. After desired turns count has been set, allow cover to snap closed. Machine motor switch, when turned to the "On" position, will allow machine to wind until white wheels in counter window indicate predetermined number of turns have been wound. At this point, counter will normally interrupt motor and simultaneously actuate braking mechanism. Winding cycle is now complete and motor switch should be turned to the "Off" position before recycling counter.

Series 6090 counters: With motor switch in "Off" position,

open the lid, lift locking lever A, depress and hold reset lever B in down position. Turn brass wheels until desired figure appears in each window. Release reset lever B, return lever A, and close lid. Turning motor switch to "On" position will start the winding cycle, which will continue until counter has subtracted preset desired count. At this point, figures will indicate zero and counter will interrupt motor and actuate stop mechanism. After turning the motor switch to the "Off" position, the counter can be returned to zero by pushing lever B down.

Series U 390 counters: With the motor switch in "Off" position, open front cover exposing resetting wheels and press recycling lever fully until it stays down. Rotate figure setting wheels until desired turns count appears in window. When cover is closed, recycling lever will automatically return to normal position. Check to be certain that correct desired number of turns appear in window, make sure that each figure is fully visible. Turn motor switch to "On" position, machine will operate until preset number of turns have been wound, reducing counter figures to zero. Stop mechanism will be actuated at this point.

Winding machines are usually operated at a high speed, and therefore considerable inertia is developed. Although braking efficiencies are very high, it is impossible to instantaneously stop the machine avoiding slight overwinding. Although slippage will occur, it will be repetitive and uniform if the winding speed is uniform. Because of the uniform braking action the number of turns overrun on the winding trial can be subtracted from the count initially set into the counter.

II. ARBOR AND CHUCK DESIGN. The design of winding arbors and chucks is very important. On many winding jobs, chucking and removing the coil form represents a considerable percentage of the total winding cycle. Hence, it represents a major part of the total winding cost. Attention to chuck and arbor design, to reduce handling time consumed, will result in cost reduction.

Fig. 24 shows a group of arbors that can be used for single layer as well as universal and progressive universal coils. In some cases the coil form is merely slipped over the round arbor and is held in place by a spring blade, while in others the form is held in place by a nut and washer. Note that threads are of the left hand type, which prevents the coil from loosening during the winding process, for top going spindles (right hand threads for top coming spindles).

The direction of revolution of a winding arbor is described as "top going" when the arbor rotates in a clockwise direction as viewed from the arbor's end. When revolved in a counter clockwise direction, the arbor rotation is referred to as "top coming."

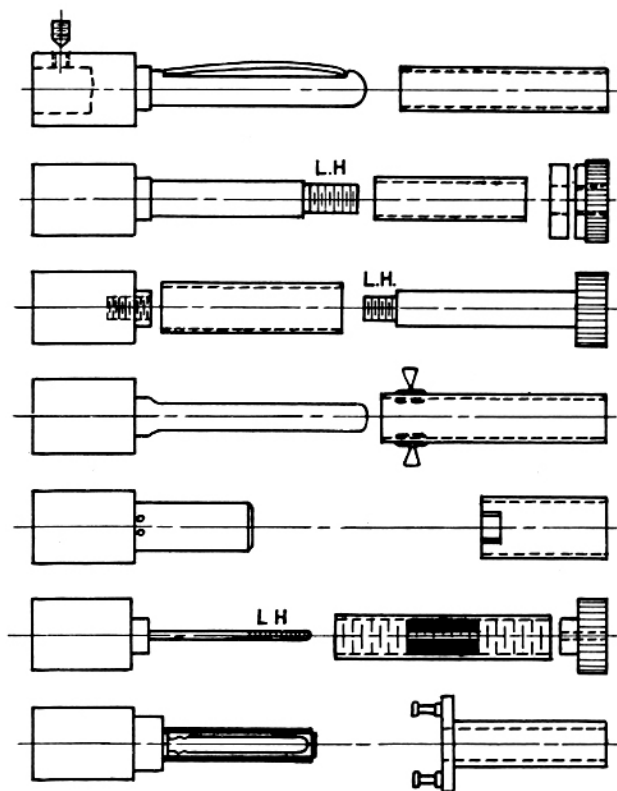

FIGURE 24—Selection of winding arbors with corresponding coil forms.

The type of arbor most suitable for bobbin winding usually consists of two parts, since, due to very high winding speeds, a tailstock is generally used. Often bobbins have a paper wall which does not provide adequate strength to resist deformation due to wire pressure. In such cases it is necessary that the arbor provides adequate support in order to prevent the form from collapsing. After the coil is wound and removed from the machine, the tension of the wire will have been properly distributed, and the paper form will fully support the winding.

Molded bobbins are generally stronger than paper bobbins, however, the tension and force of the wire is apt to break or at least deform the bobbin ends or flanges if they are not firmly supported by the arbor or chuck. A sample arbor is shown in Fig. 25. The design should match the shape of the bobbin used.

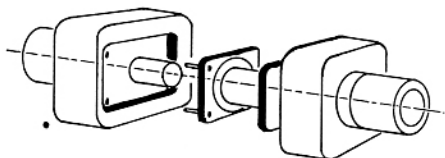

FIGURE 25—Winding arbor for bobbins.

Single layer and universal coils are often wound on solid forms which are either molded plastic or made from ceramic. A very popular ceramic form has a small wing shaped hole through its center. These coil forms usually require use of a tailstock and a suitable clamping device. Fig. 26 shows the use of a tailstock on a standard bench type winding machine, and the associated Fig. 27 shows the two parts necessary to hold a ceramic form between the head and tailstock of the machine.

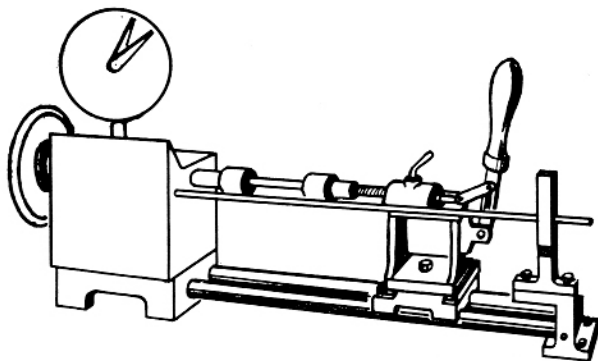

FIGURE 26—Winding machine with tailstock.

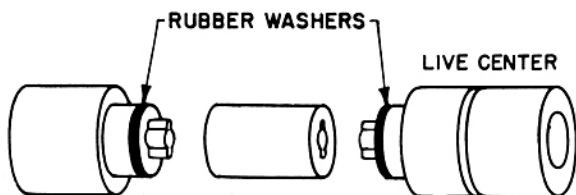

FIGURE 27—Clamping device for ceramic forms, used in connection with a tailstock.

Small solid forms, either made of molded plastic or powdered iron, especially those having molded-in wire leads, can be held on the winding machine with the aid of a chuck as shown in Fig. 28-A, or more precisely with the aid of a collet as in Fig. 28-B. The collet should be made to the form size and have a size range not greater than 15% of the total diameter of the coil form. The thread should be of the right hand type. Commonly available coil forms are usually of standard diameters, but a small selection of various size collets should always be on hand to accommodate non-standard forms.

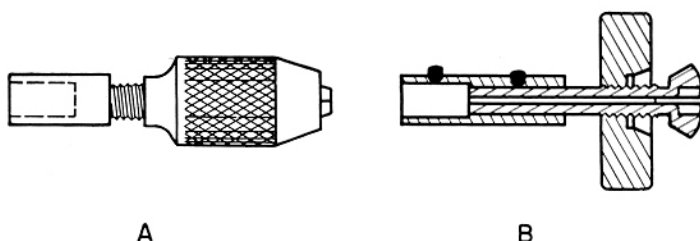

FIGURE 28—Chuck and collet.

Each mandrel, arbor, chuck and collet must have a means provided for securing the start and finish leads as well as taps of the winding. Fig. 29 illustrates a few methods which can easily be adopted to almost any design. A illustrates a simple spring blade around which the wire can be looped, B a coiled spring which is very suitable for the finest wire sizes, and C three simple pins located to assure proper location of coil start, finish, and tap when

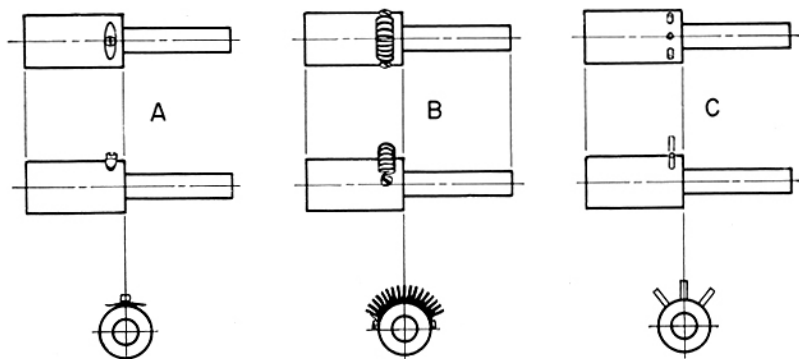

FIGURE 29—Start and tap lead securing devices.

desired. Color coding of lead location often helps during the training of coil winding personnel.

Multiple winding of coils requires special arbors. Some of the arbors shown in Fig. 24 can be extended to hold two coil forms. However, the pull of the wire is liable to throw the second coil form out of line unless a tailstock is used to support the arbor. The type of multiple arbor shown in Fig. 30 is designed to produce a large number of windings at the same time. It consists of a main rod with a driving member on one end and a thread on the other. Coil forms and spacers are alternately placed upon the rod. A nut is tightened to the threaded end of the rod holding the assembly of spacers and coil forms firmly. The loaded arbor can be inserted between the centers of the head and tailstock of the machine.

Frequently, in order to obtain the greatest output from a machine, two or three such arbors are used alternately. While the machine is winding, the operator can load the idle arbors with forms and prepare them for winding.

The spacers and the center rod have mating key and keyways in order to prevent the spacer from slipping. The spacers are also provided with pins for securing the start and tap leads. Also, all coil forms should be accurately cut to length in order that the coil position on the forms be uniform.

Multiple arbors can be designed for a great number of different types and sizes of coil forms. The number of coils that can be wound on a multiple arbor must be determined primarily from the type of coil and the number of turns to be wound. Obviously, coils requiring only a few turns, or many taps, are more easily and economically wound on a single coil winding setup.

Fig. 30 also shows the scheme of assembly of the multiple arbor as described above.

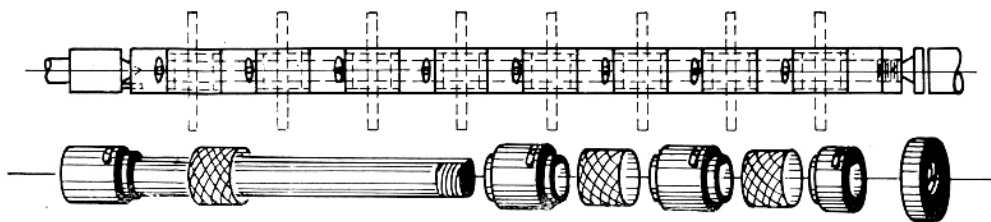

FIGURE 30—Winding arbor for multiple winding.

Almost any winding machine can be converted to multiple winding, provided the necessary additional wire guides and tension devices, as well as the special arbors, are on hand.

CHAPTER 2

MULTI LAYER WINDINGS

1. *CAM DRIVEN MACHINES.* A cam driven machine* as previously described is very suitable for the production of multi layer windings, such as bobbin coils. For the purpose of multi layer windings, the traverse rack of the machine carries two cam followers instead of one. A heart-shaped cam of proper size must be inserted and gears should be selected according to previously derived formulae. Further details and a description of a cam driven machine are given in Chapter 1, Section 2.

The problem of winding many turns of fine wire economically creates the need for a machine capable of winding at very high speeds. High speed machine operation in the range of 10,000 RPM makes it necessary that all high speed moving parts of the machinery receive regular lubrication. In addition, the machine must be as free of vibration as present machine manufacturing art will allow. Further, the winding chuck must be balanced with the coil form in position on the chuck. This is necessary because some types of coil forms have a non-uniform distribution of weight due to lug location, etc.

A high speed fine wire winding machine** is illustrated in Fig. 31. This machine has a built-in single shot lubricating system to distribute oil through a manifold to all parts of the machine requiring lubrication. Conventional cam-driven winding machine designs have been modified somewhat, still retaining the basic principle of such machines. The traverse cam and gears are located at the rear of the cast aluminum winding head.

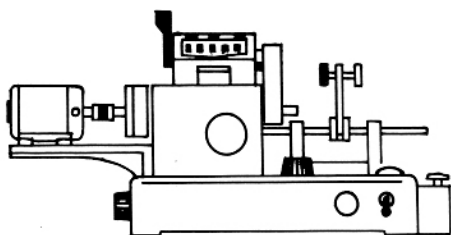

FIGURE 31—High speed, fine wire, cam driven winding machine.

*Geo. Stevens Mfg. Co. model 118

**Geo. Stevens Mfg. Co. model 38-AM

The inherent pitch of this machine and its 180° cam combined equals:

$$P = \frac{50}{c}$$

and is the result of a step down ratio of 100 : 1 between the winding shaft and the driver gear shaft. Gear ratio calculations are as follows:

$$r = \frac{t}{P}$$

$$r = \frac{tc}{50}$$

$$r = \frac{T}{50}$$

2. *THE SCREW TRAVERSE MACHINE.* Screw traverse machines are very popular. Their unlimited winding width (special machines have been made to wind 60 inch long coils), ease of setup and operation, as well as their versatility are important reasons for their popularity.

Mechanics of a screw traverse machine* are as follows: The main shaft is coupled to the driver gear shaft through a 20 : 1 reduction worm and worm gear. As in other machines previously described, the driver and driven gears are coupled by an idler gear assembly. The driven gear shaft, which extends into the gear box, is the driver shaft of a unique positive reversing gear clutch which also serves as the driver for the traverse screw.

Change of wire traverse during winding when coil extremes are reached is a function of the reversing lever (1), illustrated in Fig. 32. The reversing lever is actuated by limit screws (2), and (3), that are a part of the traverse bar (4). Movement of the traverse bar is obtained through a threaded member (5), engaged at all times to the traverse screw (6).

Winding width adjustment is made at the front of the machine by turning thumbscrews (2) and (3), adding or subtracting width as required. As one will recall, on cam operated machines, the coil width and wire size relationship were dependent upon each other to the extent that a change of either cam or wire size required a change of gearing to maintain the established ratio of traverse rate

*Geo. Stevens Mfg. Co. model 112

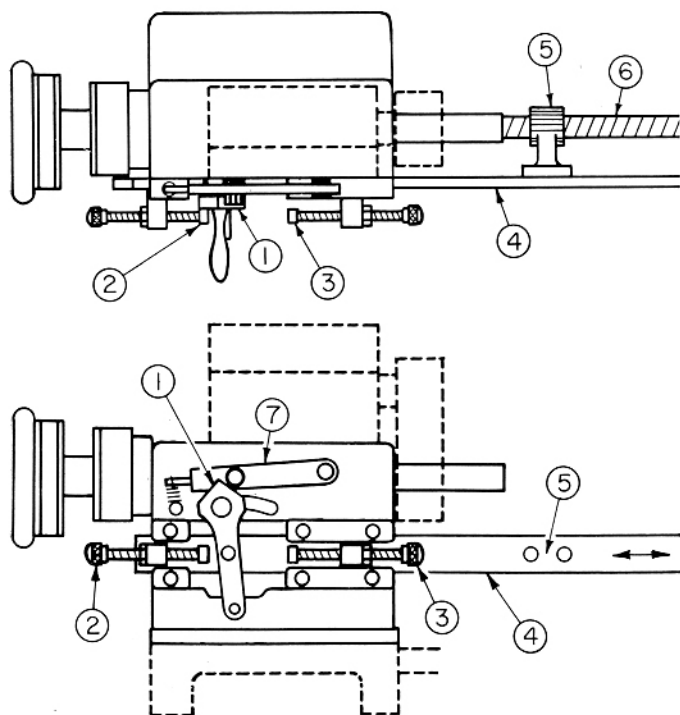

FIGURE 32—Details of a screw traverse machine.

vs. main shaft revolution. Width changes do not alter traverse ratio with respect to main shaft revolutions, therefore wire size and coil width adjustments are independent of each other on the screw traverse type machine.

Rapid reversal at extremes of traverse is accomplished by a spring activated indexing device (7) (see Fig. 32) that acts upon reversing lever (1) as soon as limit is reached. This assures uniformly wound layers with no winding pileup at coil extremes.

On occasion, particularly in the winding of relay or other fine wire coils, the fine coil wire must be attached to heavier flexible leads in order to allow assembly operations to be made without breaking coil leads. This method of coil construction necessitates insulation of the soldered connections within the coil to prevent short circuit of a portion of the winding adjacent to the soldered junction. In some cases, two or more windings may be placed on the same bobbin, and in the latter cases, the number of insulated

soldered junctions is correspondingly greater. The soldered junction and its insulation give rise to an uneven coil. The screw traverse machine can be used effectively to overcome the uneven winding by preventing traverse over the area where the diameter has been increased.

Fig. 33, an enlarged view of the reversing lever, shows a simple traverse-limiting collar that permits control of winding and results in a uniform coil height. When the collar is pushed onto lever, collar limits traverse according to collar wall thickness and when pulled away from lever, full traverse is wound. Collar design details can be taken from Fig. 33.

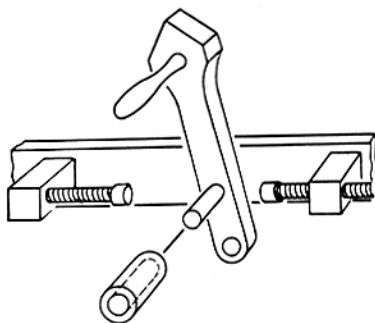

FIGURE 33—Reversing lever and limiting collar of a screw traverse machine.

As has been explained, the reversing mechanism located in the head of the machine is actuated by the reversing lever. At the exact moment of reversal during which the internal gear clutch is momentarily disengaged, the reversing lever must move over center. Force should never be used to turn the mainshaft backwards when the traverse is in either extreme position. If the main shaft is turned backwards at this time, the traverse screw will rotate in the same direction in which it was rotating prior to reversal and will, by virtue of the great power developed in the screw, force the thumbscrew against the reversing lever.

Gear ratio calculations are performed as follows:

$$r = \frac{t}{200}$$

The inherent ratio of a screw traverse type machine is based on three factors. They are: Driver gear shaft to main shaft ratio (1 : 20), traverse screw to driven gear shaft ratio (1 : 1), and the

pitch of the thread on the traverse screw proper, which enters the formula as 1 : 10. Therefore, the inherent ratio is

$$\frac{1}{20} \times \frac{1}{1} \times \frac{1}{10} = \frac{1}{200}$$

The inherent ratio of the machine equals the reciprocal of the inherent pitch P of the machine. With knowledge of the inherent ratio or inherent pitch, gear determinations for the proper wire winding pitch are as follows:

$$r = \frac{t}{P} = \frac{\text{number of teeth of driven gear}}{\text{number of teeth of driver gear}}$$

substituting the actual value for P will yield

$$r = \frac{t}{200}$$

whereby t is the number of turns per inch and is found from

$$t = 1/\delta$$

3. *HAND WINDING MACHINES.* The simplest possible winding machine to wind wire around a mandrel or coil form consists of a ball bearing shaft and headstock and means to drive this shaft. The work end of the shaft supports the winding form. The shaft is usually driven by a variable speed electric motor.

A turns counter, wire supply holder and a tension device complete the hand winding setup. A ratchet can be added to prevent the machine from turning backwards if found necessary.

Random wound bobbin coils can be made by hand guiding the wire. The additional uses to which the hand winding machine can be put are unlimited and are too numerous to detail. However, a few common types of coils produced on these machines are: Filament transformer secondaries, motor field coils, motor armatures (special chuck required), space windings on pre-grooved forms, as well as close wound single layer coils.

A varied use of the machine is in the manufacture of capacitors. Paper capacitors, for example, are usually wound around a mandrel of a certain diameter. The metal foil and the insulating paper tissues are supported on a suitable rack. The lineup of the rack and supply spools together with the above described hand winding machine make a perfect capacitor winding device. A dial counter

will enable paper sections to be wound to commercial capacitance values. Additional features can be added, such as foil and paper cutters, tape and glue supply. Inductive capacitor sections are wound by symmetric lineups of the paper and foil. Noninductive sections using the projecting foil method can be wound by adjusting paper and foil supply spools with the aid of washers having their thickness correspond to the amount of projection desired. For detailed information, the reader may refer to anyone of the numerous publications on the subject of "Paper Capacitors" or any electrical engineering handbook.

4. **HEAVY WIRE WINDING.** The problem of winding heavy wire (#5 AWG to #24 AWG) lies in guiding the wire and providing proper tension. Heavy wire tension devices* are available for use where required.

Wire guiding is done by hand on small production runs, or where production volume is large enough, by extra heavy mechanism of various design. On heavy wire coils it is important that the wire is guided in a very uniform and symmetrical fashion. Faults at the start of the winding or at the cross turns at the edge of each layer are the most common causes of coil irregularities. A rugged chuck or coil clamp, having strong walls, will help to overcome this difficulty.

It is expected that adjacent layers of a perfect lay coil show an irregularity which appears to form a helical pattern on the surface of the coil. This pattern results from the geometry of a triangular packing (perfect lay) of adjacent wires. If the tension of the wire were varied or if the bobbin changed its shape during the winding process, this helical ridge would become more and more irregular and would finally result in a totally disfigured coil. The final layers would no longer hold the specified number of turns, and the coil would exceed its mechanical dimensions if such were specified and limited. Constant tension, and a precise, rugged bobbin with corresponding arbor will help reduce difficulties.

A recommended arbor for heavy wire, self-supporting windings is shown in Fig. 34. The arbor should be slightly tapered and polished to permit easy removal of the finished winding. A groove should be provided for the entrance of the start lead as shown in Fig. 34

*Geo. Stevens Mfg. Co. models T-8, 92-12, 93-12

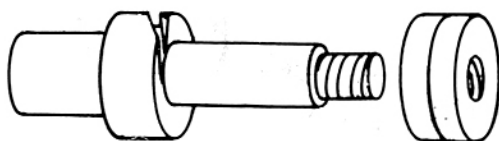
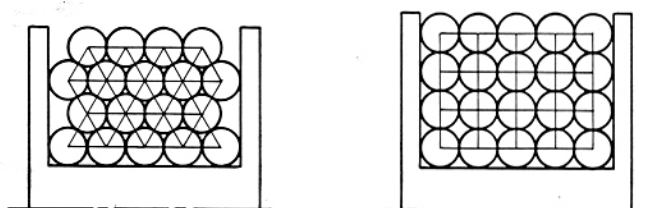

FIGURE 34—Arbor for heavy wire winding.

Note that for top going spindles the arbor should have a left hand thread in order to prevent unthreading of the nut during the winding process. Where heavy wire and correspondingly heavy tension is applied, the use of a live-center tailstock is highly recommended to distribute the load placed on the arbor between two support points.

Fig. 35 shows two methods of wire layering, the perfect lay (triangular wire packing) and the square lay (square wire packing).



PERFECT LAY

SQUARE LAY

FIGURE 35—Wire packing for multi-layer coils.

The square lay can be best performed when the winding is on a bobbin or when paper is inserted between adjacent layers.

The perfect lay will result whenever coils are wound that allow the wire to drop freely in place. The wires lie tighter and permit the construction of a self supporting coil. Fig. 36 shows a perfect lay, self-supporting coil.

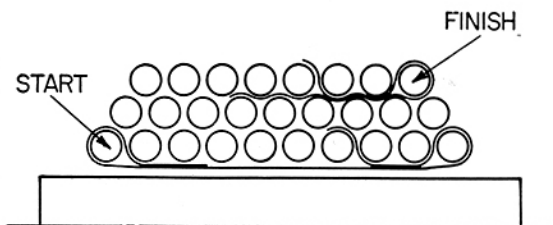

FIGURE 36—Self-supporting, perfect lay coil.

Each consecutive layer has one full turn less than the previous layer, thus giving the coil a stable support so long as the bottom layer is prevented from spreading. Spreading can be prevented by using tape. Notice that the tape is necessary for the bottom layer only and, of course, to secure the start and finish leads.

5. *MINIATURE WINDING.* Coils wound with #40 AWG and finer wire require special care, and the machines used to wind these coils must be precision built. A standard model miniature winder* is illustrated in Fig. 37.

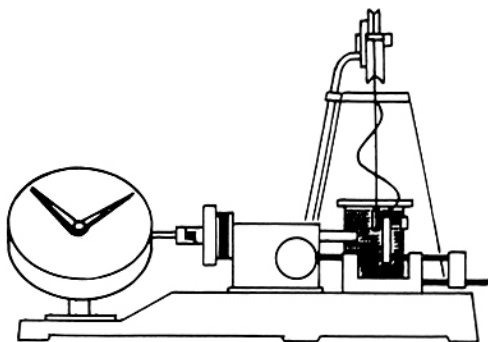

FIGURE 37—Fine wire, miniature winding machine.

The machine closely resembles what was described in an earlier section as a cam driven machine. The driver shaft is linked with the main shaft in a 1 : 100 ratio and the gear ratio required to wind a certain coil will be found from:

$$r = \frac{T}{50}$$

In general, the precautions necessary to observe are very similar to the larger cam driven machine. All values entering the gear considerations will be proportionally smaller, and yet percentage-wise, will be equivalent in accuracy. Certain additional precautions must be taken in the winding of fine wire. Although it is impossible to mention here every problem involved in fine wire winding, a few examples of common difficulties will point out the additional care that is necessary. For instance, the bobbin on which fine wire is to be wound must be free of flash marks if it is a molded bobbin—

*Geo. Stevens Mfg. Co. model 39

particularly parting flashes along the bobbin flanges on the inside winding area.

The spool on which the wire is supplied must be carefully examined prior to use to insure that, if unreeled by taking wire over the spool ends, the spool ends are smooth, not bent or nicked.

A precision micrometer, one specially adapted for wire measurement will be of help. A large number of measurements at various locations along a test length of wire should be taken.

The previously recommended method of measuring the wire diameter by winding 100 close turns and measuring the length of this winding does not apply in this case, for it is not only difficult to guide fine wire by hand to obtain a perfectly close wound coil, but the irregular tension applied during the guiding of the wire by hand causes the fine wire to stretch and even break.

Measuring the diameter therefore should be done with accurate and suitable tools such as precision micrometers, calibrated microscopes or other special apparatus.

The importance of controlled starting speed cannot be overlooked. Time spent in training the operator to carefully start manually controlled machines will pay dividends through less coil breakage and higher production output.

The desirable slow starting requirement can be performed automatically to eliminate the necessity for extensive operator training. The Stevens model 38-M, previously described, embodies a slow starting feature that is completely automatic.

6. *TEXTILE INTERWINDING.* Compact coils characterized by their high mechanical stability and minimum space requirements are known as textile interwound coils. The application for such coils is numerous although they are most commonly used in relay construction. One popular method of producing textile interwound coils makes use of a textile floss known as "Celanese" for supporting the coil which is soluble in acetone, or similar solvents. A cam driven machine is employed. The cam displacement or actual width of the winding should be shorter than the overall length of the total coil by an amount equal to the sum of both supporting walls of the coil. A highly polished winding arbor is used, the arbor, when the removable flange is in place, provides the total coil space. A layer of textile wound directly on the polished arbor is the first winding operation. A small amount of

solvent is applied to the textile winding base on the mandrel causing the celanese to adhere and provide a winding form.

Suitable arrangements of attaching the starting lead are employed, and the winding cycle is begun. Occasionally, as required during the winding cycle, celanese floss is manually inserted, concentrating the insertion at either end of the winding, thereby building up a wall. The coil continues to wind until the proper total number of turns has been wound. A protective layer of celanese floss should cover the finished coil.

7. *MULTIPLE PAPER SECTION WINDING.* Generally, a number of coils are wound on a single piece of coil tubing, with wide strips of paper inserted between the layers during the winding process. The finished "stick" of coils is sawed apart, and the start and finish leads are then pulled out of each individual section.

The recommended machine* is illustrated in Fig. 38. The traverse mechanism is driven by a traverse screw. When the traverse mechanism reaches its predetermined point, corresponding to either end of the coil width, a microswitch is actuated which

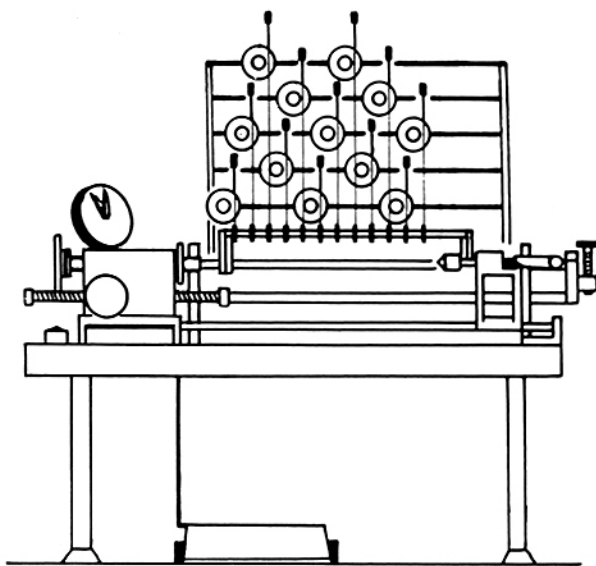

FIGURE 38—Multiple paper section winding machine.

*Geo. Stevens Mfg. Co. model 37-S

energizes a solenoid reversing the direction of the screw, thus reversing the direction of the traverse mechanism and wire guides.

The wire guides are adjustable, and the space between adjacent wire guide rollers can be set so that it is equal to the width of one winding plus the space between two adjacent windings.

To determine the proper gear ratio for any winding problem, the following formula applies:

$$r = \frac{t}{150}$$

The internal transmission ratio is 15 : 1 between the main shaft and the driver shaft. 15 revolutions of the main shaft will cause the driver gear shaft to make one complete revolution. 10 revolutions of the driven shaft will cause the traverse mechanism to travel one inch in either direction. A knob is provided at the front of the machine to allow the operator to easily move the wire traverse mechanism to any position.

Three arbors should be supplied for each machine and used consecutively. Several points regarding the wire and its supply rack bear careful consideration. The wire tension should be maintained as evenly as possible by all tension devices. Wire supply spools are usually not filled with an equal amount of wire, as a result, some spools will run out of wire more quickly than others. Replacing individual spools is very time consuming, therefore it is desirable to replace all spools at the same time. Purchasing spools having equal amounts of wire is recommended.

The tension devices are similar to the ones described previously. The spool turns, and a lever actuated brake applies friction to a drum, thus providing a controlled amount of tension. A specially designed rack holds the required number of tension devices. The rack is constructed like a stair and the devices are mounted in such a manner as to have the wires leaving the rollers of the tension arms at approximately the same angle. This setup is necessary since the operation of these devices is primarily dependent upon the angle between the wire and the tension arms.

The winding procedure can be described with the aid of Fig. 39 follows:

Place guides in the margin position and fasten wires as shown with pressure sensitive tape.

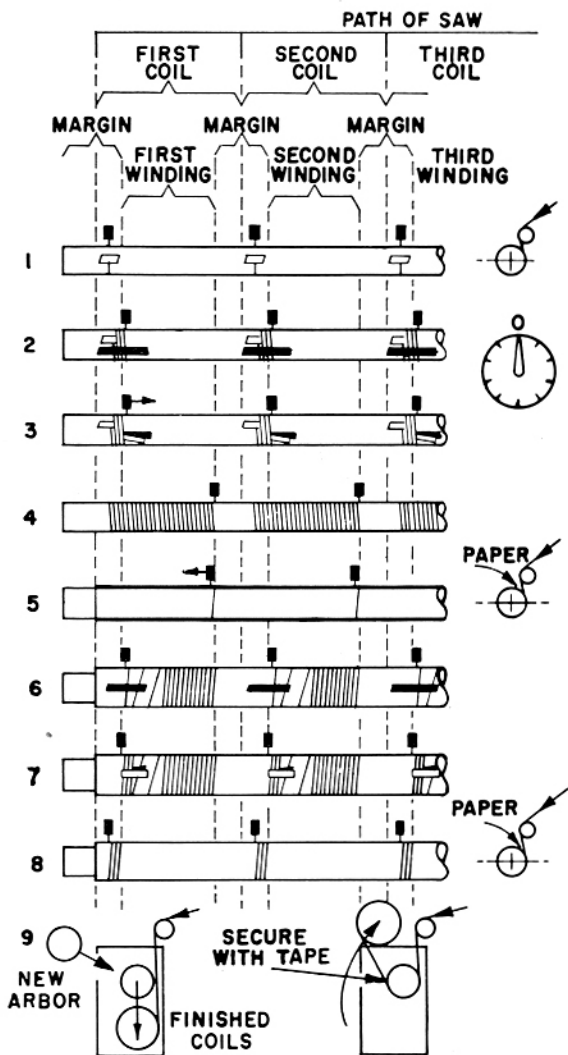

FIGURE 39—Procedure for multiple paper section winding.

Wind three turns and shift guides to the start position of the coil, then insert adhesive tape, adhesion side up. Set counter to zero. Wind one turn, cut and fold tape as shown, securing start lead of each coil. This must be done with care in order not to displace the first turn of wire.

Wind first layer. At the last turn insert first layer of paper as shown.

Wind second layer. Insert paper between each layer.

Let us assume the coil should have a tap.

Stop the machine about four or five turns before the full count to the tap location.

Shift the wire guides to the left edge of the coil and insert adhesive tape, adhesion side up.

Wind the finish turn to the tap, cut the tape and fold over as shown.

Insert a layer of paper and wind at least three turns of wire in the margin.

Then shift the wire back to the start position, insert tape, wind the first turn, cut the tape, fold over and wind the remainder of the coil, always inserting paper between each layer.

Use the same procedure to finish the winding as for placing the tap lead in the margin. When the wire guide is moved to the margin, one long strip of adhesive tape should cover the whole length of the coil thus holding the finish lead in place. Remove the whole arbor from the machine without cutting the wires. Insert a new arbor. It will be simple now to place and secure the start leads since their lineup is provided by the finished arbor.

Finally, the sections are cut apart by a band saw using a special paper cutting blade and a suitable jig. Care must be exercised to cut into the margin and not into the winding. It is often desirable to cover the coils with a final layer of heavier paper. After the finish turn is completed and before the guide is shifted to the margin, a layer of gummed kraft paper should be inserted. A few additional turns, wound on top, will hold the kraft paper until the glue is dry.

When shifting the guides into the margin, care must be exercised so as to not wind in the path of the saw. The turns wound in the margin will provide the wire for the start and finish leads.

When inserting the paper (kraft paper or glassine paper is common) care must be taken so that the paper will not wrinkle. It will understandably wrinkle if the wire tension is unequal.

The insertion of paper can be done by a well trained operator

without stopping the machine after each layer. The paper is pre-cut and is fed by hand.

In pre-cutting the paper, various lengths should be provided since the coil circumference increases with the addition of each new layer.

A heavy roll of paper can be mounted beneath the table. The paper is fed in front of the operator over the edge of a table. A blade is used to cut the paper on the table from which it can be inserted into the winding at the very moment one layer is completed.

A tape dispenser should be provided to supply tape in a horizontal direction, parallel to the arbor.

Manually operated marking knives, which are set to the width of the coil desired, can be used after the winding process has been completed.

The vacuum process of impregnation of these paper sections is highly recommended.

CHAPTER 3

THE UNIVERSAL TYPE WINDING

1. **CONSTRUCTION.** The universal type winding is used exclusively in the radio field. Electrical currents at frequencies higher than 20,000 cycles per second require a more careful design of coils. In order to minimize dielectric losses, to reduce the distributed capacitance and to increase the Q -Factor of a reactor, the universal type winding and in limited cases the progressive universal type winding are highly recommended.

Whereas the layer wound coils have their wires wound parallel to each other in a right angle to the axis of the coil, the universal coil has its wires crossing each other. These run in an angle of about 75° to 80° to the coil axis, and the geometry of such a winding results in the construction of a coil whose wires are self-supporting.

As illustrated by Fig. 40 the wire starts at point (1), runs across the coil surface to point (2), and continues along the circumference of the coil to reappear at the top of the coil, as shown in the drawing, where it passes over the first turn at point (3). At point (4), it changes direction to again run across the surface of the coil.

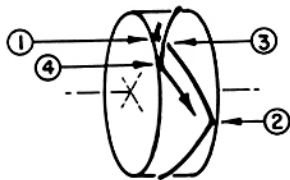

FIGURE 40—Construction of the universal winding.

As will be noticed from Fig. 40, there is a slight distance between the two adjacent changes of direction, point (1) and point (4), at the coil edge. This distance or progression at the coil surface is responsible for a stable mechanical construction of the winding.

The sketch in Fig. 40 actually represents a universal type winding with four changes of direction per turn, or to use the more popular terminology, the winding shows four crossovers per turn. The selection of the correct number of crossovers per turn is of fundamental importance in coil design and is discussed in a later section of this chapter.

The process of winding a universal coil is such, that while the coil form turns continuously, a small button guides the wire from one edge to the other and back. This button is mounted to a shuttle mechanism and its movements are directed by a heart-shaped cam. The rotation of the cam is directly related to the rotation of the coil form by means of gears. This relationship is expressed as a ratio. For example, the cam can be geared to rotate only half a turn or through 180° while the coil form rotates one complete 360° revolution. In this case the ratio will be:

$$360 : 180 = 2 : 1$$

The scheme in Fig. 41 illustrates the principle of a universal winding machine.*

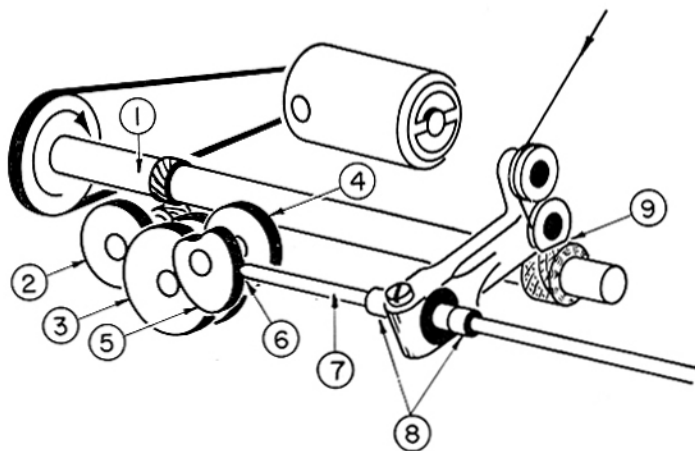

FIGURE 41—Mechanism of a universal winding machine.

We have in number (1), the main shaft which is rotated by a motor. Number (2), is called the driver gear and it is mounted on the driver shaft. The latter is coupled to the main shaft with the aid of two helical gears. Number (3), is called the idler which links the driver gear to the cam gear, the latter being marked (4). The cam gear and the cam, (5), are mounted to a common shaft. At point (6), the tip of the shuttle rod (7), rides on top of the cam surface. While the cam rotates around its shaft, this tip and the whole shuttle mechanism (8), moves first from left to right and

*Geo. Stevens Mfg. Co. models 120, 125, 220, and 225

then from right to left and so on, continuously oscillating. Thus, the shuttle is permitted to guide the wire to the correct location on the coil surface (9). While winding, the coil diameter will enlarge with increasing turns. Therefore the shuttle mechanism is also made movable up and down, the center of its movement is the shuttle rod.

2. *GEARS AND CAMS.* Gears are marked in accordance with their number of teeth, and cams are marked with the length of excursion expressed in decimals of one inch.

40,000 and more gear combinations can be mounted in a universal gear box using a conventional set of gears ranging from 20 teeth to 120 teeth and a standard set of idlers (1:1; 1:2; 1:3; and inversely).

This large number of gear combinations clearly indicates that it is time saving to select by calculation the one desired gear combination that matches a specific coil design, rather than to try various combinations of a limited selection of gears and achieve a compromise selection by trial and error methods.

Cams usually range from 0.032 up to 1.250 inch, in steps of 1/64 inch. The shape of a cam is rather critical and requires a precise layout. Fig. 42 shows the curve of a heart-shaped cam for a universal type winding, which is linear in respect to the degree of rotation.

Special cams, having two or three maxima and minima can also be used, but are very uncommon. Non-linear cams, such as sinusoidal types, do not provide the necessary mechanical stability for a self-supporting coil and are therefore limited to one-layer coils. They are frequently used for the progressive universal type winding.

In order to make the shuttle follow precisely the cam shape, it is necessary to match the tip of the shuttle rod to the cam used. Standard cams for 1/4 inch shafts are milled with a 3/16 inch diameter milling cutter. By cutting these cams, the center of the cutter describes the exact line, while the cutting edge determines the appearance of the cam. See Fig. 7 (Chapter 1, Section 3). In order to make the shuttle follow the true cam line, its tip must have the same radius as the cutting tool. A tip to match standard cams therefore will look like Fig. 43.

A non-matched tip and cam pair will cause the wire to slip, form an irregular coil and cause turns to drop.

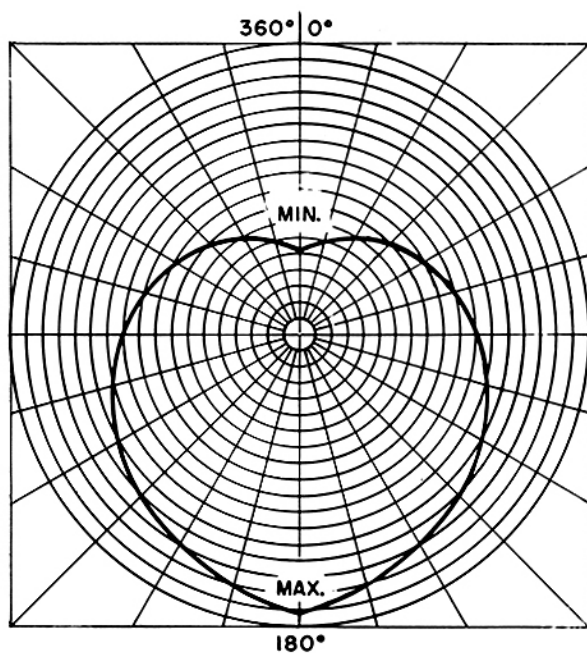

FIGURE 42—Layouts of a heart-shaped cam.

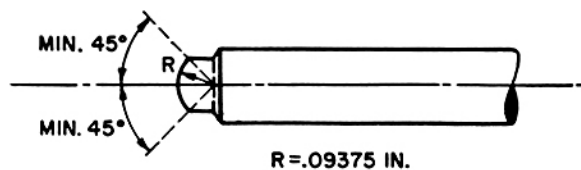

FIGURE 43—Cam follower for standard universal, heart-shaped cams.

The shuttle mechanism must be free of play, and the tip must press against the cam with just sufficient force to prevent the tip from jumping. This alignment has to be done with more accuracy than is usually necessary for all other types of windings. Lubrication must be provided, Metallic Lubricant HT-3 or equivalent and felt rings provided near the tip are recommended.

3. *GEAR BOX SETUP.* The gear box, as shown in Fig. 44* contains a driver gear (1), a bracket with a set of idler gears (2), a cam shaft with a cam gear (3). A spacer and a cam are not shown in Fig. 44.

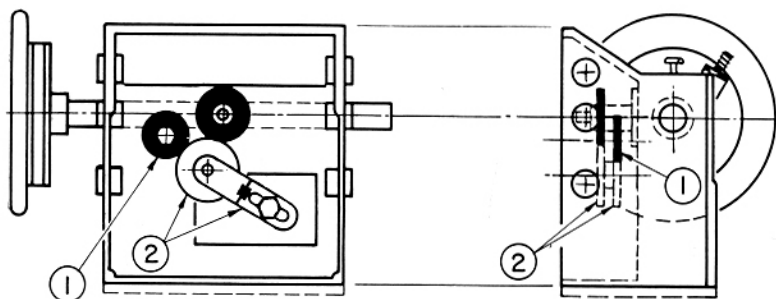

FIGURE 44—Universal gear box, location of driver-idler and cam gears.

After mounting and tightening the driver gear, the cam gear can be pushed over the cam shaft. The spacer and the cam will follow. A lock washer and a hex-nut secure the cam and gear to the shaft. A pin inserted through the gear box top and cam shaft prevents the cam shaft from turning during the alignment procedure.

Next the idler is loosely screwed against its mounting plate. By turning the hand wheel of the machine in the winding direction with the left hand, the right hand can firmly press the idler gears to mesh the driver and cam gears.

Continuous turning of the hand wheel will indicate how much tension of the idler gears is necessary to provide a smooth operation. Binding and grinding gears will cause rapid wearing and a rather noisy operation.

*Geo. Stevens Mfg. Co. models 120 and 125

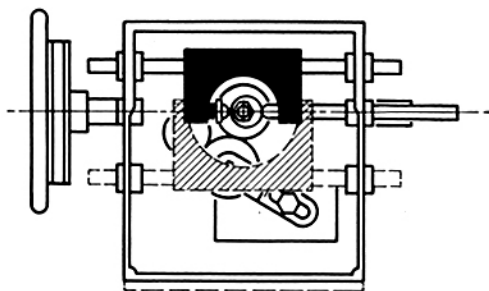

FIGURE 45—Universal gear box, mounting of shuttle yokes.

Finally the shuttle yoke goes into place as shown in Fig. 45. Its rods should be kept free of wax and cement (often used with or near the machine as part of the total operation to secure the finish leads), and they should be free of burrs and move easily and evenly through all bushings. Two types of yokes are recommended: One for cam sizes ranging from 0.032 to 0.750 and one for cams from 0.750 up to 1.125 in. as shown. (Resp. 1.250 in. for larger machines*).

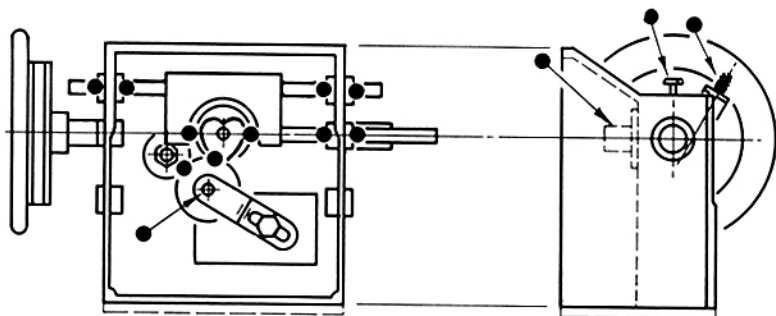

FIGURE 46—Universal gear box, points of lubrication.

The shuttle rod and the wire guide mechanism should be properly adjusted and all points of friction should be sufficiently lubricated (See Fig. 46). All exposed machine parts should be kept free of oil in order to enable the operator to produce clean and oil-free coils. The exposed non-moving parts are enameled, the enamel used being oil and wax proof and able to withstand all solvents used in the coil manufacturing process such as acetone,

*Geo. Stevens Mfg. Co. model 220

alcohol and trichlorethylene. The enamel is also resistant to many chemical wire stripping solutions.

4. *WIRE GUIDE ADJUSTMENT*. Much attention must be given to the wire guide and its adjustment. Fig. 47 shows different types which are in use at the present time.

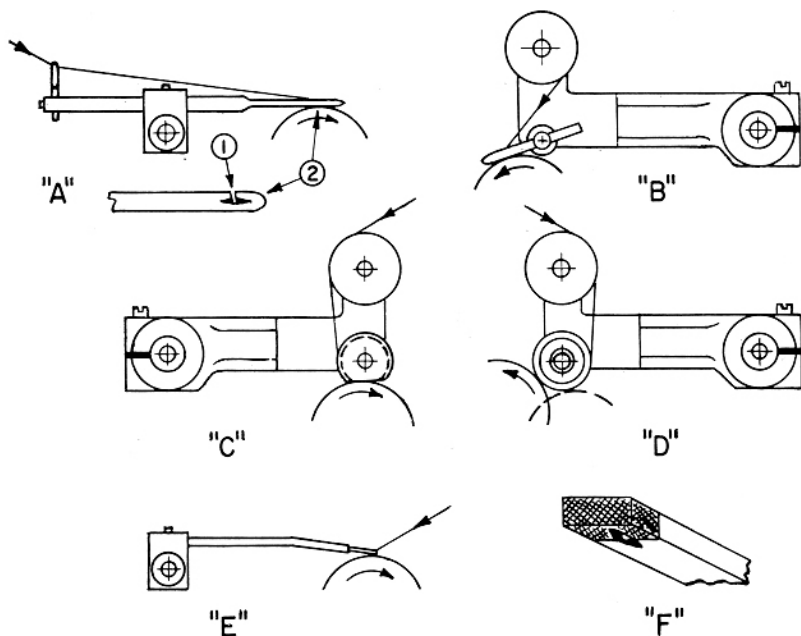

FIGURE 47—Various types of universal wire guides.

A, illustrates the so-called "winding needle" with or without the slot (1), in the "eye" (2). B, shows the most versatile "combination winding eye" used on large disc windings (high voltage coils). C, shows a typical winding "button" used in varying widths. D, illustrates a "winding roller" which is, of course, limited for use with the specific wire size for which each roller is designed, and consists of a cylinder with ball bearings and a small groove cut in the circumference to guide the wire. This type does not need adjustment and is therefore recommended for coils with large increasing diameters. Its relatively large weight is not conducive to rapid operation. Finally, E shows a simple "winding finger" and F, a rather expensive winding needle featuring a "carballoy tip."

The adjustment of these various types of wire guides is in many respects critical. All guides have one thing in common: the port of exit, or the point where the wire leaves the guide and finds its place in the coil. The winding needle, containing the eye, requires very careful attention. Fig. 48 shows the construction of the eye.

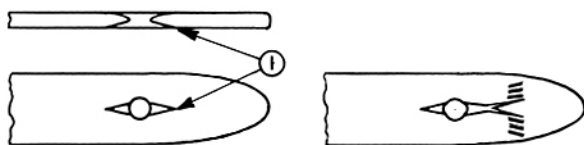

FIGURE 48—Condition of winding eye.

Point (1), although requiring reasonably smooth edges, must run out in a sharp, definite and symmetric form. The bottom side must be smooth and free of grooves. Eyes which should be replaced will show a double groove caused by wear from the wire passing through it, as seen in Fig. 48.

Winding with glass-fibre insulated wire causes needles to wear very rapidly, and it is recommended that carballoy tips be used. Buttons as shown in Fig. 47-C can easily be re-ground on a surface grinder. Buffing of all wire guides is a necessity. Surface hardened (electrolyzed) guides wear longer than others.

The wire guide will touch the coil surface at a certain line. Perfect parallel alignment of the guide in respect to the center of the coil shaft is required. See Fig. 49.

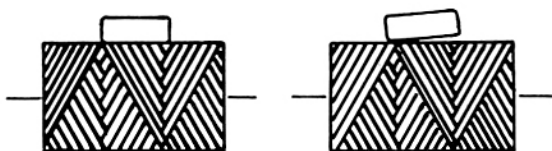

FIGURE 49—Parallel alignment of wire guide.

The port of exit has to be in a definite position to the line at which the guide touches the coil, as demonstrated in Fig. 50.

Dropped turns and stripped wire insulation are most commonly caused by incorrect guide settings.

5. *GUIDE PRESSURE.* The nature of a universal winding requires that the wire guide force the wire into its place with a slight pressure. This guide pressure must be maintained within certain limits during the entire winding process.

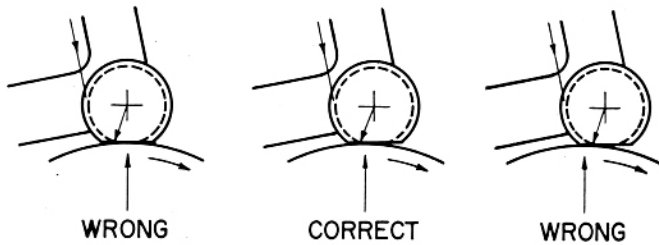

FIGURE 50—Tangential alignment of wire guide.
Observe the location of the part of exit in respect
to the point of tangency.

Most wire guides, as previously described, supply the necessary pressure partially by the weight of the guide and partially by the tension of the wire which, when transformed by the lever action of the roller, adds to the initial weight.

The amount of pressure added by the wire tension will increase when the tension increases. Some devices, however, increase their tension when the winding speed increases. Thus a fast winding speed may cause universal windings to flatten and even cause turns to drop. The conventional winding arm also increases the pressure when the coil diameter increases. Thus it is obvious that an improper combination of wire guide and tension device resulting in incorrect guide pressure can cause many difficulties.

The winding finger, for example, does not provide this lever action. In this case it is the friction of the passing wire which forces the guide against the coil. Smooth wire and slow winding speeds together with the use of constant tension devices require the use of small springs or rubber bands in order to hold the finger against the coil surface.

The winding needle can be modified by attaching a roller directly above the shuttle shaft, as illustrated in Fig. 51. The same modification can also be done with the winding finger.

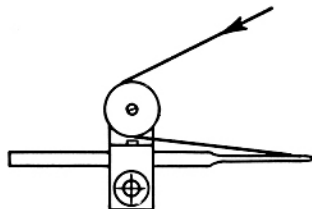

FIGURE 51—Modified winding needle. Highly recommended for progressive universal windings.
(See Chapter 4)

6. *DISC WINDINGS AND FLYBACK-COILS.* Fig. 52 illustrates the problem involved in winding a universal coil whose diameter increases during the winding process. This problem is encountered when winding high voltage television transformers.

At the start of the winding, the guide appears to be properly adjusted and touches the coil near the port of exit. The port is near the point of tangency of the circle. However, with increasing coil diameter, the guide rises, and the port of exit separates from the point of tangency. Finally, the wire guide loses its function because the port has risen above the coil and is now separated by a distance sufficient to allow the wire to slip and drop.

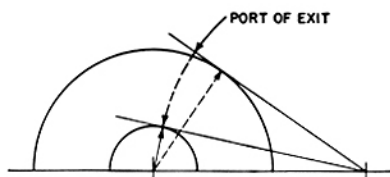

FIGURE 52—Misalignment caused by the rise of the port of exit with increasing coil diameter, as encountered during the winding of typical flyback-coils.

Of course, the guide could be adjusted initially for the maximum diameter of the coil to be wound. However, this adjustment would be incorrect for the first layers of the coil and would result in an irregular pattern at the beginning. A mechanically stable and uniform winding of the initial layers is essential if a large self-supporting coil is to be built. The whole problem reminds one of the more classical example which deals with the proper placement of pickup arms and cartridges on phonographs. Here also, a specific start location and angle of tangency to the circle must be found.

The geometrical analysis of the required relationship between the port of exit and the point of coil tangency may be summarized in the following words to form a simple rule of thumb. Refer to Fig. 53:

Imagine a line drawn between the center of the shuttle rod "A" and the center of the coil shaft "B".

From the center of the coil shaft, 90° to the line AB, imagine another line, BC. Then visualizing the diameter of the coil form to be doubled, place the guide button in a position parallel with AB so that

the guide would be tangent to this doubled diameter and would touch at point "C".

Note that at the start of the winding, the guide rests toward the rear of the coil.

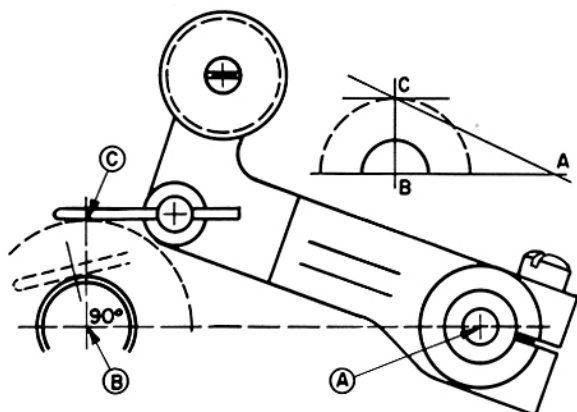

FIGURE 53—Rule of thumb for the proper alignment of a combination wire guide.

The conventional type wire guides are not designed to permit this adjustment. The combination winding eye, as shown in Fig. 47-B is recommended. The so-called winding roller, Fig. 47-D is very massive and therefore not frequently used nor recommended. The finger-type, however, can easily be bent into shape and is very helpful in laboratory work where setups are frequently and rapidly changed. In production, the finger-type wears rapidly, and its replacement makes it necessary to repeat the whole adjustment procedure, which is time consuming and therefore costly, especially where multiple machines are used.

Disc windings contain many crossovers per turn, which means that the shuttle will move frequently back and forth while the machine slowly adds one turn to another. Multiple setups are recommended for economy of operation. The gear selection must be chosen, however, with many considerations, of which further details may be found in Sections 16, 17, and 18 of Chapter 3.

7. THE BEHAVIOUR OF VARIOUS WIRE INSULATIONS. Served wire, such as nylon-textile serving, is most suitable for universal winding. Cclanese-textile and silk-textile have

a tendency to strip easily while running through tension devices, rollers and eyes. Impregnation of this type of coil is very effective as an aid to coil stability and for reducing electrical losses due to humidity.

Most types of wire are shipped and supplied with a thin film of oil on their surface. The removal of this oil is a necessity where coated wire (no textile serving) is used to wind universal coils. A trichlorethylene degreasing process may be applied if precautions are taken. Long exposures of the wire to the solvent must be avoided. It is very necessary that the wire be absolutely dry when it is wound into the coil or storage spool. Dusting the wire with natural rosin provides in addition good adhesion properties during the winding process.

As mentioned previously, the wire must lie at an angle of 75° to 80° to the coil axis. With a nylon-textile insulated wire, degreased and rosin covered, angles of less than 75° may be obtained. This possibility should not be forgotten when large diameter coils (disc-windings) are to be produced.

The use of plain-enameled copper wire is not recommended since the insulation is too soft. Formvar*, Nylonenamel, Nylclad*, Solderze* and Solderex*, Celenamel* and a few others are suitable. Teflon insulated wire is rather slippery and is not recommended. All textile served wires are ideal for universal winding purposes.

Stranded wires can be wound as well. However, it should be remembered that only round wires will provide a clean and faultless winding. Litz wire with 7, 19, 37, 61, etc. strands are the only symmetric types, and their cross section, together with the textile serving, most closely approaches a perfect circle. Here again, a carefully considered compromise between mechanical uniformity and electrical performance should be made.

8. *WINDING SPEED AND PRODUCTION SETUP.* In predetermining the maximum winding speed of a universal winding operation, which is expressed in revolutions per minute, the following limitations to the top speed should be considered:

1. The shuttle mechanism is subjected to speed limits which depend upon the cam size being used.

*Trade names

2. The heavier wire sizes will apply a greater opposing tension to the winding torque of the machine, the latter driving with a speed limited by the power of the motor rather than as a result of the other factors.
3. The finer wire sizes obviously require a great deal more care and more attention during the winding operation. The winding speed will mainly be limited in this case by the type of tension devices and reelers being used.

By careful analysis of all operations which are to be performed by the operator on the winding machine, production time may be greatly improved. It should be remembered that all operations not necessarily related to the actual coil winding process, should be taken away from the machine operator in order to keep the machine operating productively at all times. However, during long coil runs (coils with many hundreds of turns) the operator can devote spare time to additional job operations.

The basic machine operations are: Chucking the coil form, securing the starting lead, adjusting the counter and switch settings, winding, tap placing (where taps are required), securing the finish lead, and removing the finished coil.

The facility to rapidly chuck a coil form is a requirement of good chuck design. Refer to Chapter 1, Section 11. Also the start lead must be secured to the chuck. The placing of a tap requires excessive delaying of the machine. A small needle (crochet) with a hook allows easy and even twisting of the wire. The finish lead can be secured the most rapidly with wax or pressure sensitive tape or fast drying cements, depending upon the type of impregnation material used later. Also, taps can be secured with wax or tape. However, tape should not be used on coils wound with fine wire since the thickness of the tape will appreciably deform the cylindrical shape of the coil resulting in winding irregularities. A tap can be knotted by a skilled operator so that it will not require any tape or wax. See illustrations in Fig. 54.

The location of the winding machine and its related equipment is of indisputable importance. The machine, for example, should not be assigned a permanent location in the company. A so-called winding department does not always prove to be most efficient. Universal machines are bench models and can be inserted into the production line at the most expedient location. Shelves nearby for wire storage are desirable.

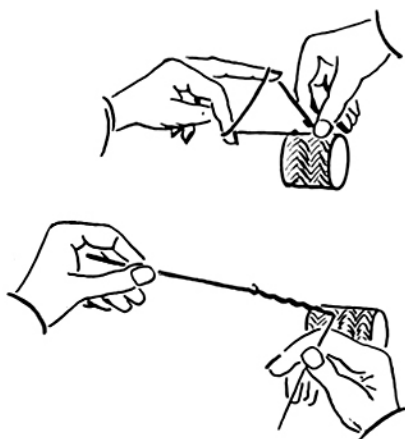

FIGURE 54—Tap knotting and twisting.

A model setup for winding coils may look as illustrated in Fig. 55.

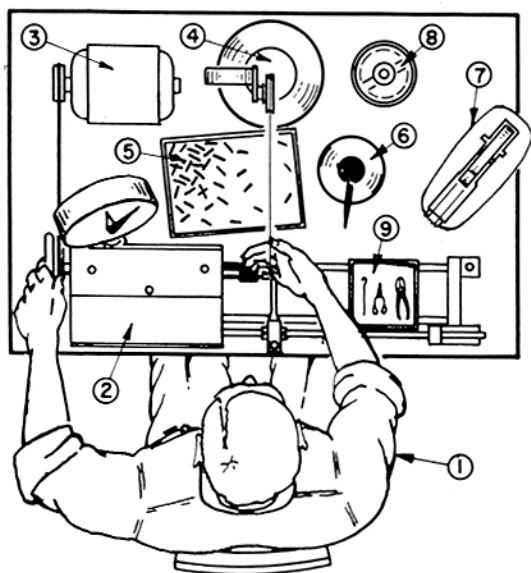

FIGURE 55—Typical coil winding setup.

Fig. 55 shows in (1), the operator, (2), the machine, (3), the motor, (4), the wire supply and tension device, (5), the coil form

supply box, (6), the wax pot and a brush, (7), a tape dispenser, (8), spare wire, and (9), a board for tools located on the machine.

Multiple setups are recommended for coils requiring long running periods. However, if a coil requires one or more taps, the advantage of multiple setups is questionable. A multiple chuck and additional wire guides and tension devices are usually all that is required to change from single to multiple setups.

9. *PI-WINDINGS*. Winding devices for pi coils vary from simple setups to semi-automatic machines. The sizes of coils vary from tiny $\frac{1}{4}$ inch diameter coils (TV peaking coils) to large high voltage pulse transformers as used in TV sets or other scope equipment.

The production of pi coils can be accomplished by two basically different methods. The first method requires shifting the wire guide from one pi position to the next, while the coil form remains in its original position. In the second method the position of the wire guide remains stationary, and the coil form is shifted instead.



FIGURE 56—Various types of pi-windings.

Shifting the wire guide can be done very simply as shown in Fig. 57. The winding arm, mounted to a bushing, rests against a sleeve lock on its left hand side as illustrated in the sketch. A long cylindrical coil spring applies pressure against the arm-assembly to keep it in this first position. This would be the position of the arm-assembly for winding the first pi. After completion of the first pi, a spacer is inserted between the arm-assembly and the sleeve lock. The finish lead is carefully shifted from the first pi to the start of the next pi. This is done by turning the coil shaft in winding direction for about one-fourth of a turn by hand while inserting the spacer.

The third and fourth pi are made in the same manner. The width of a spacer is equal to the dimension a as shown in Fig. 56.

The spacer resembles a horse-shoe. This method of spacing is simple and sufficient for small quantities or experimental work. An improvement of the same basic principle employs a bushing which has sawtooth-like steps. Again, a spring holds the wire guide

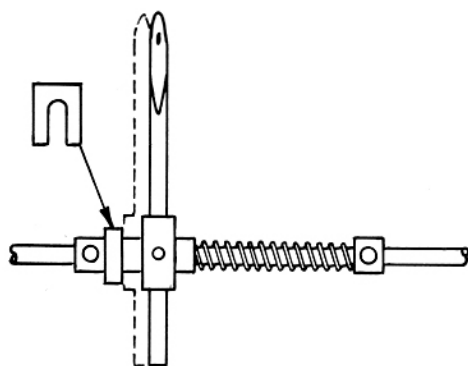

FIGURE 57—Pi-winding method employing a horse-shoe spacer.

in its proper position for winding each separate pi. When shifting from one pi to the next, the guide or arm will simply be pushed until the spring-blade snaps into the next position, see Fig. 58.

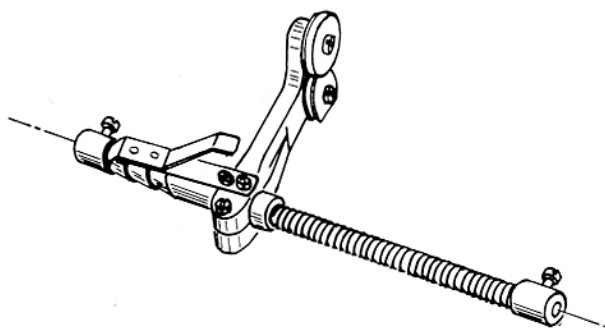

FIGURE 58—Pi-winding method employing a step bushing.

The two previously described methods have but one disadvantage; the winding speed is limited. At and above certain shuttle frequencies, the pressure of the coil spring will be overcome by the force of the shuttle striking against it, thus displacing the shuttle from its true cam line and resulting in dropped turns. Because of this limitation, the use of the horse-shoe or step-bushing is not recommended for winding high voltage coils or disc windings where a higher number of crossovers per turn results in high shuttle frequencies.

The second method, as mentioned at the beginning, features

a fixed shuttle mechanism and instead moves the coil form from one pi to the next, thus removing the concern of shuttle frequency.

The winding machine is of a different design. It closely resembles the type of winding machine used in winding progressive-universal coils. The machine has a hollow main shaft carrying a telescope-like extension inside. The arbor with coil form is mounted at the end of this extension. A bearing allows the extension to be guided freely by a rack.

Fig. 59 shows the function of a typical progressive-universal machine. The bearing, arm and rack comprise an assembly which is moved in one direction by a pinion gear. The latter gear rotates proportionally to the number of main shaft revolutions. Gears located in the progression gear box determine this relationship. The crank in front of the machine is mounted to the pinion-shaft and a simple clutch assembly. Rotation of this crank returns the rack to its starting position.

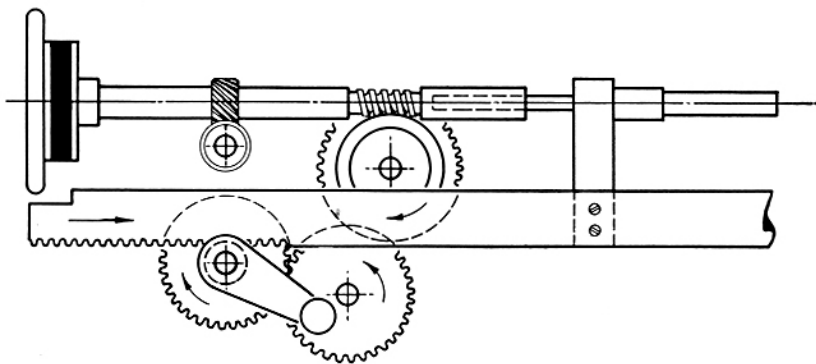

FIGURE 59—Principle of a progressive universal machine.

Disassembling or disengaging the gears in the progression gear box enables the operator to shift the coil form from one pi to the next simply by turning the crank. Provisions for holding the rack and form in the desired position while winding one pi must be provided. Either a notched disc or special cam can be mounted to the back of the machine in place of the driven gear and a ratchet mounted in place of the idler can be used to hold the disc in place. An attachment to the rack similar to a comb in connection with a spring-pin assembly will also do the job. Both attachments are shown in Fig. 60.

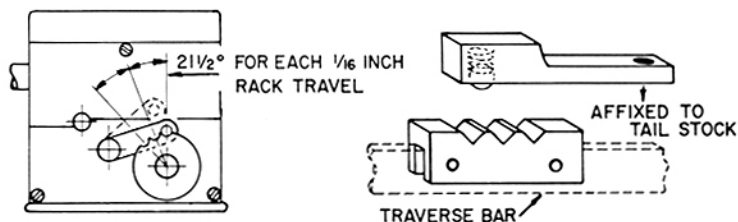

FIGURE 60—Various pi-winding attachments used in connection with a rack driven machine.

The most advanced method employs a very versatile machine similar to the progressive-universal type. The rack and telescopic shaft are also the same as used with the universal winding type mechanism. However, in this case the rack is not driven by a pinion gear but by a large cam. The machine is described and illustrated in Chapter 4, Section 5.

For the purpose of winding pi coils, a step-cam can be mounted on the shaft. The distance a as explained at the beginning of this chapter will be represented by the difference in radius of each section cam. The cam will have as many sections as the number of pi-sections to be wound, plus one return section. The rack is spring-operated in this case. The gear ratio in the progression gear box, which determines the relation between the cam and coil rotation, will also determine the number of turns per pi. If each cam section has the same angle γ , each pi will have the same number of turns. Otherwise, the ratio of the number of turns of one pi to the other will be equivalent to the ratio of one section to the other expressed in angular degrees.

The great advantage of this machine lies in its speed. It is not necessary, for example, to stop the machine while shifting from one pi to the next, since the machine performs its function automatically. An automatic stop assembly consisting of a counter and switch plus an automatic brake makes this machine perfect for large quantity production.

10. *THE DESIGN OF A STEP-CAM.* The step-cam and its layout (polarcoordinated and rectangularly coordinated) as shown in Fig. 61, is typical for a three pi coil having an equal number of turns for each pi.

The 360° of the cam are divided into four sections, one for each pi plus one retrace section. The retrace section should cover a distance sufficient so as to limit the angle for the rack to climb to

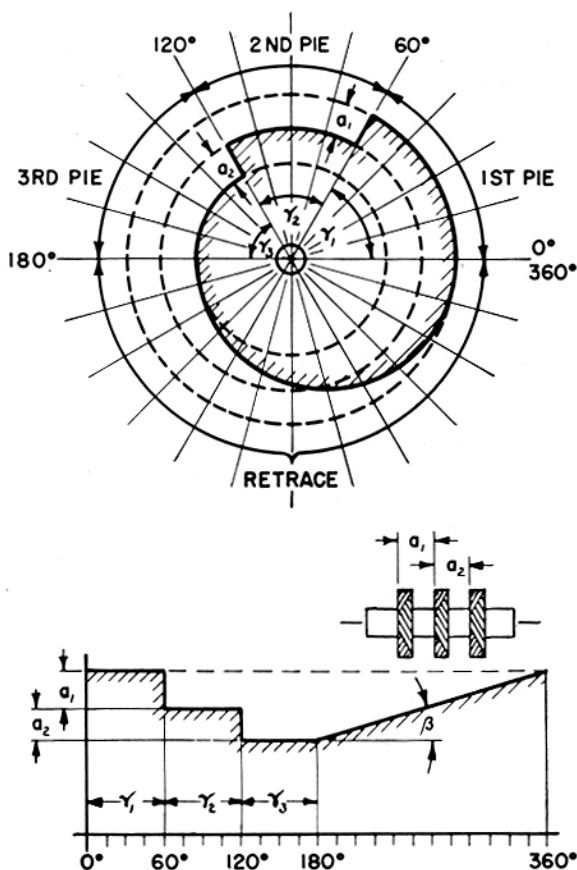

FIGURE 61—Layouts of a step cam, employed for winding pi-coils.

not greater than $\beta = 30^\circ$. Commonly the retrace section occupies at least one third of the cam circumference, but preferably one half or 180° as shown in the sketch.

The gear drive in the back of the machine will be such that the 180° active cam rotation will be performed during the winding of the whole coil. This means that a pi coil, having a total number of $3 \times V$ turns, will require such a back-ratio so as to provide one half of a cam rotation during $3 \times V$ main shaft turns. A standard model winding machine is already provided with a transmission ratio of 100 : 1 between the drive shaft and the main shaft.

We refer to the ratio of the number of teeth of the cam gear to the number of teeth of the driver gear as r_b (this case deals with the back-gears only) and will result in the equation:

$$r_b = \frac{(V_1 + V_2 + V_3 + \dots) \times 360}{100 \times (\gamma_1 + \gamma_2 + \gamma_3 + \dots)}$$

Simply stated, the gear ratio equals the ratio of the total number of turns divided by 100 multiplied by the fraction of the active cam section.

Example: 3 pi-sections totaling 198 turns,
 First pi has 66 "
 Second pi has 66 "
 Third pi has 66 "

Since the retrace section occupies 180° , each of the pi-sections will occupy 60°

To select our proper gear combination we equate

$$r_b = \frac{(66 + 66 + 66) \times 360}{100 \times (60 + 60 + 60)} = \frac{71280}{18000} = 3.96 = 4 - 0.04$$

Referring to the table of reciprocals

$$0.04 = 1/25,$$

By substitution

$$r_b = 4 - \frac{1}{25} = \frac{100}{25} - \frac{1}{25}$$

$$r_b = 99/25$$

Therefore our proper gear combination should consist of the following

Cam gear: 99 teeth
 Driver gear: 25
 Idler gear: 1 : 1

In a case where the number of turns varies from pi to pi, the total number of degrees of active cam rotation must be divided into varying sections.

The following example explains the construction of a four pi coil having a different number of turns in each pi and using a cam which has a 120° retrace section, leaving 240° for active cam rotation.

Example:	4 pi-sections totaling	218 turns
	First pi has	80 "
	Second pi has	68 "
	Third pi has	50 "
	Fourth pi has	20 "

Active cam rotation : 240°

$$\frac{240}{218} = 1.10092^\circ \text{ per turn}$$

$$80 \times 1.10092 = 88.07360^\circ \text{ (88 degr.*)}$$

$$68 \times 1.10092 = 74.86256^\circ \text{ (75 degr.*)}$$

$$50 \times 1.10092 = 55.04600^\circ \text{ (55 degr.*)}$$

$$20 \times 1.10092 = 22.01840^\circ \text{ (22 degr.*)}$$

(*The precision of the cam-cutting machine will determine the required degree of accuracy).

The exact gear ratio can be determined by following the procedure described in the previous example after entering the total amount of active cam rotation in the denominator of the formula for r_b .

11. THE WINDING OF IF-TRANSFORMERS. Universal windings are employed at the standard intermediate-frequencies which fall in the range below 4,5 megacycles. The usual IF-Transformer consists of two windings on one coil form which are in a definite electrical relationship to one another, usually defined as coupling and in practice measured in terms of mutual inductance. The value of this coupling often results in a very critical mechanical problem, since both windings are wound in parallel, and the mechanical distance between them determines the amount of electrical coupling.

A typical IF-coil is shown in Fig. 62. Both windings must not be identical in their number of turns. As a practical measure they will have the same width, since this allows both coils to be wound

at the same time on one winding machine using the same cam and gear setup.



FIGURE 62—Typical IF-transformer windings.

Two wire guides are operated on the same shuttle shaft. The start and finish leads for both coils are secured at the same time, and both coils are wound simultaneously.

Fig. 63 shows a highly recommended setup* as seen from above.

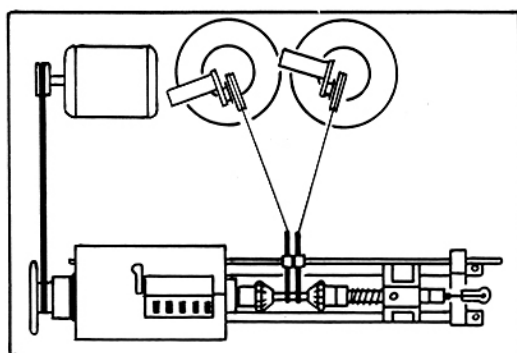

FIGURE 63—IF-winding setup, as seen from above.

Notice that two needle wire guides are employed and that this type of machine has its wire guides and shuttle in the rear and shows the operator sitting in front directly facing the coil. The tailstock release is foot operated. Fig. 64 illustrates the type of coil clamp used to assure most rapid operation.

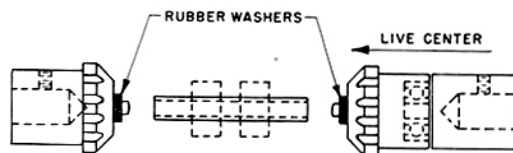

FIGURE 64—Clamping device for IF-winding, see text.

It consists of two parts; one driving member attached to the main shaft, and one live center bushing, attached to the tail stock of the machine. Both parts, as shown in Fig. 64, feature a notched shoulder. When starting a winding, the start lead is simply pulled over the corresponding shoulder. Slight finger pressure, applied against the smooth section beyond each shoulder, will cause the start lead to wind itself onto the smooth section during the first few revolutions.

After winding a few turns, the crossing turns of the universal winding will have sufficiently secured the first layer thus preventing the coil from loosening. The finger pressure can be released and the winding operation be completed. The type of coil clamp described eliminates the need for extra lead securing clips, and the method used reduces time spent for lead securing, thus cutting the cost of the product.

Of great aid in winding IF-coils is a threaded bushing supporting one of the wire guides. Frequently it is desirable to have a rapid means of changing the distance between both windings. The threaded bushing in connection with a tapped wire guide arm, as shown in Fig. 65, will do the job well.

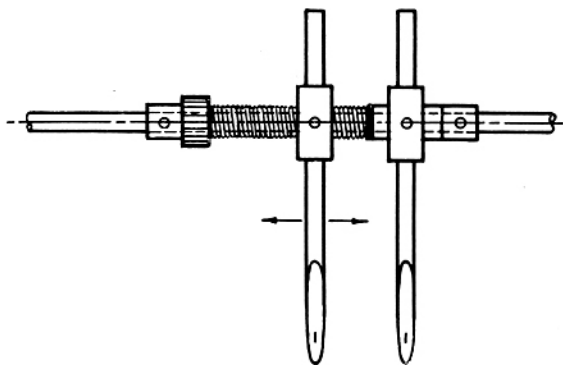

FIGURE 65—Mechanical means for the control of coil spacing.

Often times a problem arises where both windings are required to be wound with different wire sizes. It is possible to wind both selections at the same time if the difference in both wire sizes is not too great. The larger wire size value should be applied to the universal gear formula in this case. Gears which will provide a tight winding for the larger wire coil, are usually satisfactory for the smaller wire coil also. Consideration must be given in a case

like this, where the wire guides will rise at different rates. Sufficient play between both guides is therefore very essential.

Where both sections having the same size wires are wound very closely together, the guiding needle frequently must be reshaped in order to clear the neighboring section. Coils can even be wound side by side and made to touch each other by spacing the two wire guides exactly one cam size apart. The guides in this case will slip over the neighboring coil. If the guide is smooth and even on its lower face, no damage will occur. In this case the use of a threaded bushing becomes necessary, since differences of less than $1/64$ inch will distort the even appearance of the coil.

12. *UNIVERSAL BIFILAR*. Bifilar windings, frequently used in ratio detector circuits, can be made without difficulty in the universal style. The wire guide should have a sufficiently large port of exit to permit both wires to pass in parallel. From the types of guides shown in Fig. 47, type A is the most suitable, next is the simple finger-type shown under E. The other types are not recommended.

Two separate wire tension devices must be provided, and it is advisable to space both devices, one on the left side and one on the right side, in order to prevent the wires from crossing and tangling with one another while winding.

Various colored wires are often used to favor easy assembling. Wires of different sizes can be wound in parallel if the difference in size is not too great. The use of one textile-served coated wire and one bare coated wire is quite popular.

The gear combination should be calculated or taken from the alignment charts in the appendix. However, the value for δ , the total wire diameter, should be the sum of the two single wire diameters.

13. *HONEYCOMB WINDINGS*. In the early days of radio, the honeycomb winding was in fashion. This coil can be compared to our present universal winding, except that it is provided with a large spacing between wires. Selecting the correct gear combination and observing a few simple precautions, this type of coil can be wound on a standard universal winding machine.

In addition to the large wire spacing, the winding is characterized by a straight wall pattern. See Chapter 3, Section 17. The progression between adjacent crossovers at the coil edge is chosen

to be very large, and it is a relatively simple fraction of the circumference of the coil. Each individual turn of the winding cycle is exactly covered by each corresponding turn of the following winding cycle, thus leaving large openings on the surface of the coil.

This type of winding is still in use where low distributed capacitances are required of coils which are limited to the shape of a universal coil for mechanical or electromagnetic reasons. However, the progressive universal coil has taken the lead in popularity where low loss coils are required.

14. OSCILLATOR COILS AND C — WINDINGS. Frequently oscillator circuits use coils which have a tank winding adjusted to plus or minus $\frac{1}{2}\%$ accuracy in inductance together with a feed back winding or small interwound capacity winding.

The inductance may be varied by merely bending the coil in or out of shape. The Q-Factor will suffer as a result, however, fortunately it is not of too great importance with this type of coil. It will be found that by squeezing in toward the center of the coil, the inductance will either go up or down. The direction in which the inductance changes depends mainly on the original shape of the coil. Squeezing the opposite sides of the coil will cause it to change in the opposite direction. Trial and error will provide the basic rules for the proper direction of squeezing.

To build these coils so that squeezing will be effective, the gear combination should be such as to provide relatively loose winding. The gear formula will have to be chosen for a larger value for δ , the total wire diameter. The same rule applies, should the alignment-charts be used.

15. SELF-RESONANT COILS. The popular "peaking coils" used in TV sets belong to this class of coils. The distributed capacitance and the true inductance of the coil form a tank circuit which resonates at a specific frequency. By changing the capacitance (which is always small compared to the inductance) rather than by changing the inductance or number of turns, the coil can be brought to the desired resonant frequency. A grid dip meter will help to achieve the desired resonant frequency. Varying the gear combinations to obtain a tighter or looser winding, varying the cam sizes or the number of turns per layer will provide sufficient range. Various impregnating materials should also be considered since their dielectric constants range from 2.5 to 7. Uni-

form coil form diameters and uniform impregnation must be provided for production purposes.

16. **GEOMETRY.** Observing the surface of a universal coil, it will be noted that the wire crosses from one edge of the coil to the other and that after one or a multiple of one complete turn, the wire passes close to the starting point, thus completing one winding cycle.

The term *crossover* is applied to each straight section of wire crossing the coil surface. Each change of direction that the wire undergoes at either coil edge while guided by the cam minimum or maximum shall be referred to as a *bend*. A stable and self-supporting coil will be obtained only when the angle between the wire and coil axis is within 75° to 86° , the recommended optimal value being 78° .

This means that the number of *crossovers per turn*, signified by the letter n , will be determined by the tangent of 78° , the coil width c , and the circumference d of the coil form, as follows:

$$\tan 78^\circ = \frac{\pi \times d}{n \times c} = 4.705$$

Fig. 66 illustrates the geometrical layout of a coil surface pattern, having two crossovers per turn.

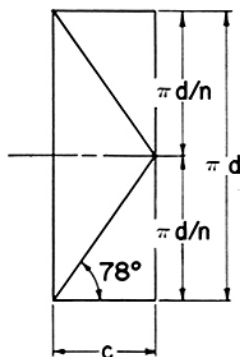

FIGURE 66—Geometry of the universal winding.

$\pi \times d/n$ is the circumferential distance from one bend to the next, as measured on the coil surface perpendicular to the coil shaft. Therefore solving for n we have

$$n = \frac{\pi \times d}{\tan 78^\circ \times c}$$

$$n = .666 \frac{d}{c} = \frac{2 \times d}{3 \times c}$$

Fig. 66 also illustrates that the winding cycle of a coil having two crossovers per turn is completed after one turn. For other numbers of n , winding cycles can have more than one turn. A list of various patterns can be found in Section 17.

The product of the *number of turns per winding cycle* and the *number of crossovers per turn* yields the *number of crossovers per winding cycle*, designated by the letter q .

After the completion of one winding cycle, there will be noted a small progression between bends of adjacent wires at the coil edge. This progression together with the angle between the wire and coil axis is highly responsible in obtaining a mechanically stable coil. The amount of this progression per winding cycle depends upon the cam and wire size in addition to the characteristics of the coil pattern.

We shall identify the center spacing between two adjacent turns, as measured *parallel* to the coil axis, by the letter s . Let us assume that the desired center spacing is

$$s = 1.25 \times \delta$$

where δ is the total wire diameter including all insulation. Since the coil width equals c (measured between the centers of the extreme outside wires), we will have

$$c/s = c/1.25 \times \delta$$

being the number of wires or turns appearing on the coil surface.

If we now observe that each wire lying on the surface must undergo a bend when reaching either coil edge and that such a series of bends equivalent in number to the number of wires on the surface, will occupy the length $\pi \times d/n$ (See Fig. 66), we can say that n times this number will be the total amount of bends designated by the symbol N , which crown the coil edge for 360°

$$n \times c/1.25 \times \delta = N$$

Fig. 67 shows the appearance of one double layer with N bends on either edge.

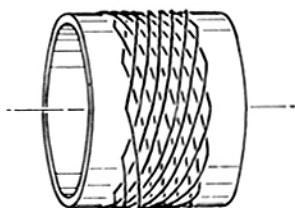

FIGURE 67—Appearance of one double layer, universally wound.

As N is the number of bends per circumference, Nq/n will be the number of bends per winding cycle, since q/n is the number of turns per winding cycle. Therefore

$$\frac{N \times q}{n} = \frac{n \times c \times q}{1.25 \times \delta \times n} = \frac{c \times q}{1.25 \times \delta}$$

The reciprocal of Nq/n will be that fraction representing the progression observed on either edge after the completion of one winding cycle

$$\frac{n}{N \times q} = \frac{1.25 \times \delta}{q \times c}$$

The gear ratio designated previously as r is

$$r = \frac{\text{rotation of coil shaft (in degrees)}}{\text{rotation of cam shaft (in degrees)}}$$

which is equivalent to

$$r = \frac{\text{number of teeth of cam gear}}{\text{number of teeth of driver gear}} = \frac{z_c}{z_d}$$

r consists of a basic and significant ratio, plus this small amount of progression. Since each cam rotation provides two crossovers the gear ratio will be

$$r = 2/n + x.$$

The progression per winding cycle will also be affected by $2/n$, so we can rewrite the equation above to read:

$$r = 2/n + \frac{2 \times n}{n \times N \times q} = 2/n + \frac{2 \times 1.25 \times \delta}{n \times q \times c}$$

By counting N and n of a given coil, the left hand formula can be used to recalculate the gear ratio used in winding a certain coil. The right hand formula is suitable for coil design and was first expressed by Dr. A. W. Simon as follows:

$$r = (2/n) [1 \pm 1.25 \times \delta/c \times q]$$

The following Fig. 68 will aid in the understanding of the geometrical problem

- c = cam size = coil width
- d = coil form diameter
- δ = total wire diameter
- n = number of crossovers per turn
- q = number of crossovers per winding cycle
- $\pi \times d$ = circumference of coil, equal to one coil turn of 360°
- w = length of one winding cycle
- y = circumferential length occupied by one crossover

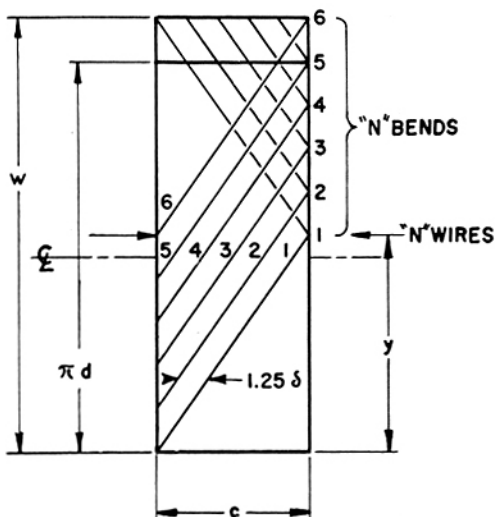

FIGURE 68—Surface pattern of a universal winding.

The example shows a surface pattern where

$$n = 2 \quad \text{and} \quad q = 2$$

17. *SURFACE AND WALL PATTERNS.* It will be found that a woven layer of a universal coil actually consists of two layers of wire. The woven layers may be thought of as similar to the layers of a roll of tape.

The layering will be called progressive if the sequence of bends advances opposite to the winding direction*, see Fig. 69-A, it will be called retrogressive if the crossovers advance in the winding direction, see Fig. 69-B.

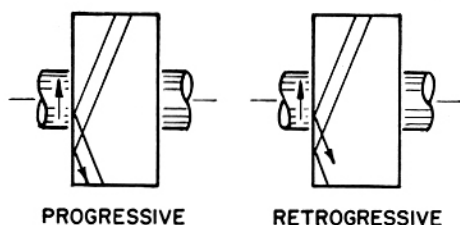

FIGURE 69—Types of universal layering.

Progressive gear ratios are larger than the ratio $2/n$, retrogressive ratios are smaller. Both type windings have the same mechanical stability, electrical differences are negligibly small, so that the choice of either one is merely a matter of preference.

A universal winding will be self-supporting only if the angle between the wire and coil axis lies between the indicated limits. However, the described angle increases as the coil diameter and its circumference increases. It is therefore necessary to select the number of crossovers per turn in such a way as to provide the smallest possible angle at the start of the winding, that is preferably 78° .

*As found on Geo. Stevens Mfg. Co. models 120, 125, 220, and 225

An alignment chart in the appendix is given to aid in the selection of the proper number of crossovers per turn n .

Once the number of crossovers has been determined, another alignment chart specifically for that number of crossovers is provided, and with δ and c , being known quantities, the gear ratio r can be found very easily.

Looking at the side of a universal coil, a wall-pattern will be noticed which is formed by the bends of adjacent layers of wire. Two types of wall-patterns, spirals or spokes can be found. See Fig. 70.

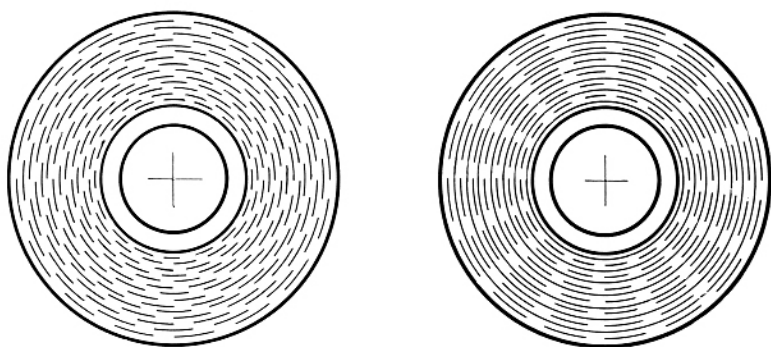

FIGURE 70—Wall patterns of universal windings.

An integral number of bends counted at one edge of the coil will result in spokes, since the bends of one layer come to lie exactly atop of the bends of the previous layer. A non-integral number of bends will result in spirals. A slight curvature noted on the spokes is due to the circular rise of the winding arm.

It may happen during the process of winding that the tension of the wire will twist the layers closer to the center. An irregular wall-pattern will appear as a result, and electrical characteristics will then vary from coil to coil. Careful wire tension adjustment will eliminate this occurrence.

The number of layers per coil will be equal to the total number of turns, divided by the number of turns per layer.

The number of turns per single layer will be equal to the number of spokes or spirals divided by the number of crossovers per turn.

The number of single layers per coil will provide some data to predetermine the distributed capacitance of a coil, provided the insulation and impregnation are analysed with respect to their dielectric properties.

In production, uniformity and speed are two desirable qualities brought to the coil designer's attention. In order to keep an accurate turns count, it is helpful for the winder to start the coil with the guide in the left hand position at all times. Often the start and finish lead and tap have a certain location on the coil form, and start and tap should be performed with the guide always in the same position. This can be done easily by selecting a gear ratio and a turns count to conform to the following rule:

Select an integral number of bends at the coil edge,
and

Select the number of turns as an integral multiple
of the number of turns per woven layer.

Fig. 71 shows a selection of various patterns, each signified by its number of crossovers per turn. The pattern represents the approximate position of the wire center, neglecting the progression. It shows the face of one complete winding cycle.

Each pattern is accompanied by:

$$\begin{aligned} n &= \text{number of crossovers per turn} \\ q &= \text{number of crossovers per winding cycle} \\ q/n &= \text{number of turns per winding cycle.} \end{aligned}$$

In general, it can be said that patterns like the one for $n = 2$ will provide a tight layer packing, and those like $n = 1\frac{1}{2}$ will be loose packed and therefore provide less distributed capacitance.

A loose wire packing also can be obtained by entering gear ratio considerations with a larger value for δ , the total wire diameter.

The wire diameter including all wire insulation should always be measured before δ is entered into either one of the formulae. An accurate measurement will be obtained by winding a close-parallel coil of 100 turns of wire (guide the wire by hand). Measure the length of this coil with a conventional steel-ruler having a fractional inch scale and convert into decimals. The number obtained divided by 100 will give a very accurate value for δ .

This procedure is generally recommended since wire tables do not give uniform data for the thickness of the wire insulation.

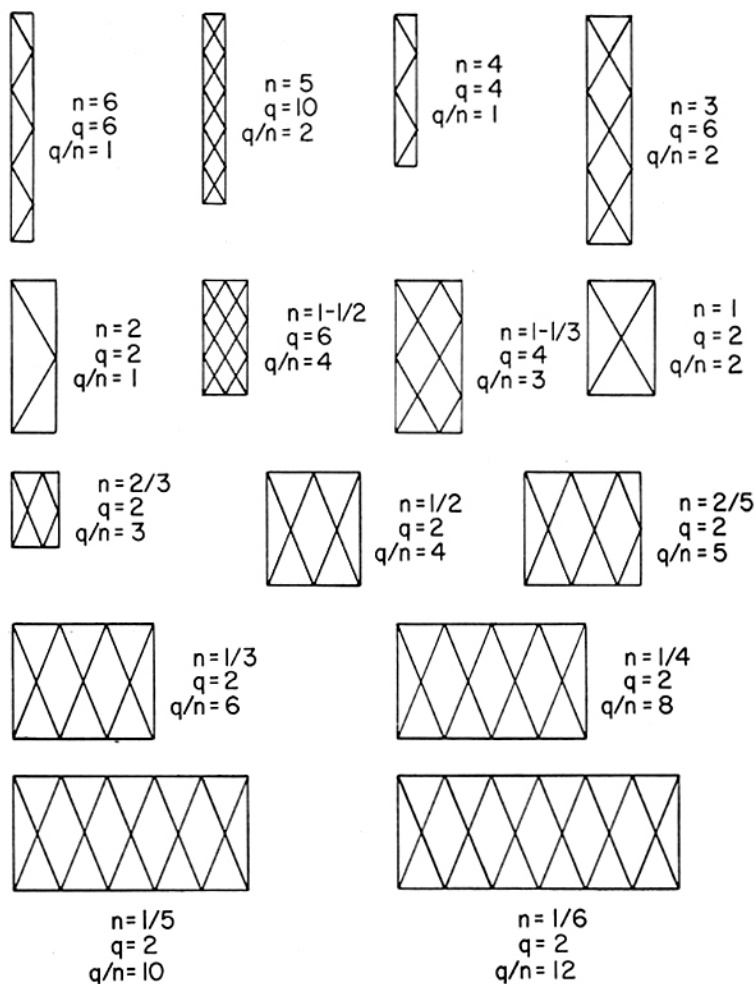

FIGURE 71—Recommended surface patterns for universal windings, see text.

18. THE PRACTICE OF GEAR RATIO AND GEAR SELECTION.

Nomenclature:

n	=	number of crossovers per turn
r	=	gear ratio; cam gear over driver gear
δ	=	total wire diameter including insulation
c	=	cam size equiv. to coil width
q	=	crossovers per winding cycle
d	=	coil form diameter

The first step is the selection of the number of crossovers per turn. It is

$$n = \frac{2 \times d}{3 \times c}$$

n will turn out to be a fraction or a whole number plus a fraction. It is advisable to choose the nearest smaller whole number or simple fraction or whole number plus a simple fraction in order to obtain a good pattern. The layout of patterns in the previous section will help in finding a suitable value for n .

The value of q will be found to be twice the numerator of

$$\frac{n}{2}$$

where the fraction is written in its lowest terms. For the value of $n = 2$ (for example), $n/2 = 1/1$ where 1 is the numerator and $2 \times 1 = 2$ is the value for q . For $n = 3$, $n/2 = 3/2$ and $2 \times 3 = 6 = q$. Or we have $n = 2\frac{1}{2}$ and $n/2 = 2\frac{1}{2} : 2 = (5/2) : 2 = 5/4$, and we will find 5 being the numerator and $2 \times 5 = 10 = q$ being the value sought.

With all values known at this point we can use the formula from Section 16.

$$r = (2/n) [1 + 1.25 \times \delta/q \times c]$$

The accuracy with which each value should be considered is as follows: The wire diameter should be measured accurately to four places. For the finest wires five places behind the decimal point are sufficient. The coil form diameter expressed in 1/1000 of an inch with $\pm 10\%$ will suffice. The cam size given in 1/1000 inch can be read from the cam itself. Finally r should be calculated to at least four places for windings with textile served wire, to five places for plain coated wire.

Once the gear ratio has been determined, a set of gears should be found whose ratio of teeth is equivalent to r . The simpler way to do this is to use a slide rule. The ratio is set on the D scale, and a point is sought at which one whole number on the D scale and one on the C scale coincide. The example in Fig. 72 shows a ratio $r = 2.0666$ set on the D scale and the coinciding numbers 62 on the D scale and 30 on the C scale, where 62 will be the cam gear and 30 the driver gear. This method, however, is highly inaccurate and should be followed only for rough estimates.

A better method of finding the proper set of gears employs a table of reciprocals. As will be found in most cases, the ratio r will consist of a whole number plus a simple fraction. The whole number will be recognized as being equal to $2/n$ and the fraction as the additional $(2 \times 1.25 \times \delta) : (n \times q \times c)$ which we call x in order to simplify the explanation. Now we have

$$r = 2/n + x$$

By looking up the table of reciprocals we will find the value of x or a reasonably close value as a fraction. For example, $r = 1.0161$ which is $r = 1 + 0.0161$ and our x will be 0.0161, $r = 62/62 + 1/62$ which equals $r = 63/62$, exactly the gears we were seeking. The fractions can also be found with the aid of a slide rule.

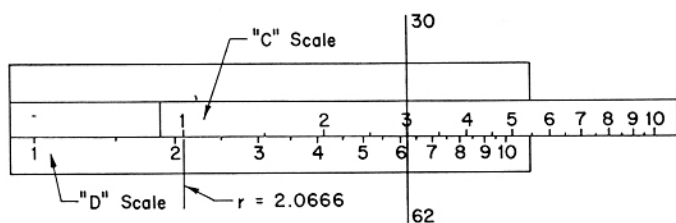

FIGURE 72—Selection of gears by means of a slide-rule.

Often the significant number for $2/n$ cannot be found so easily. The knowledge and study of various possible patterns therefore is of great help. The gear ratios for retrogressive layering, for example, will look somewhat different. It is

$$r = 2/n(1 - 1.25\delta/qc) ; r = 2/n - x$$

In other words, the fraction will be subtracted from $2/n$.

For various numbers of crossovers we will have

	<i>Progressive</i>	<i>Retrogressive</i>
$n = 1/6$	$r = 12 + x$	$r = 12 - x$
$n = 1/4$	$r = 8 + x$	$r = 8 - x$
$n = 1/3$	$r = 6 + x$	$r = 6 - x$
$n = 1/2$	$r = 4 + x$	$r = 4 - x$
$n = 1$	$r = 2 + x$	$r = 2 - x$
$n = 1-1/2$	$r = 4/3 + x$	$r = 4/3 - x$
	etc.	

Finally it should be pointed out that it is wise to spend some time and effort to calculate and select gears carefully. With conventional sets of idler gears, over 40,000 gear combinations can be mounted in a standard gear box. To find the proper combinations just by trial and error is rather time consuming.

CHAPTER 4

THE PROGRESSIVE UNIVERSAL WINDING.

1. *THE CONSTRUCTION OF THE PROGRESSIVE UNIVERSAL WINDING.* The progressive universal winding can easily be visualized by recalling the construction of the universal type winding. Remember that the layers of a universal winding are similar to the layers in a roll of tape, and that if the center layer of a roll of tape is pushed out, and the other layers are made to follow, the roll of tape will become a tube whose wall is a continuous spiral of tape.

The construction of a progressive universal coil is almost identical to this spirally formed tube of tape. Each layer is woven in the previously described universal winding manner. Simultaneously, while the wire guide is oscillating, the rotating coil form moves axially in one direction, passing the wire guide, thus forming the coil as interwoven layers of wire in a continuous spiral.

Adjacent layers of woven wire may either overlap each other, or they may touch one another, or there can be a space between them. The coil consisting of overlapping layers is of prime interest.

The amount of overlap necessary for a given wire size should be determined first, since the length of the winding and the number of turns are usually the fundamental data from which the coil must be constructed. The wire size and form diameter are next in importance. A compromise between these values, which permits a favorable amount of overlapping, should be most desirable. If the allowable length for the winding is called l and the total wire diameter is δ , we will have

$$l/\delta = T$$

If we denote by W , the total number of turns for the completed coil, the factor expressing the overlapping will be equal to W/T .

Best results are obtained when the W/T factor is a little less than two. When the factor is slightly more than one or a little over two, the wire will slip and form an irregular winding. If the factor is less than one, a single layer winding should be employed. When the W/T factor is larger than three, the resulting coil will usually have an ugly shape.

The universal cam should be selected so as to provide at least five turns of wire per cam throw. The number of turns per cam

throw for a tight progressive universal winding will be considerably less than the number of turns per cam throw on regular universal coils. This is due to the increased spacing between adjacent turns of wire in the progressive universal coil.

Fig. 73 shows a typical progressive universal coil.

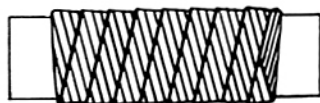

FIGURE 73—Typical progressive universal winding.

As the coil form rotates, and the shuttle mechanism guides the wire in its predetermined place, weaving a typical universal coil pattern, the progressive mechanism moves the coil form past the wire guide, parallel with the oscillating motion of the wire guide. The progression of the coil form is directly related to the revolving main shaft by which it is carried and rotated. The rate of progression is determined by interchangeable gears, mounted on the rear wall of the machine head.

These progression gears establish the revolution of the rack pinion in relation to the main shaft. The pinion, in turn, drives a rack which moves the coil past the oscillating wire guide. The oscillations of the wire guide are caused by a revolving heart-shaped cam, the revolution of the latter being directly related to the revolution of the main shaft by means of interchangeable gears mounted inside the gear box on the front of the machine head.

Simply stated, the progressive universal winding machine is a combination of two previously described machines, the rack driven machine and the universal winding machine.

2. *THE PROGRESSIVE UNIVERSAL WINDING MACHINE.** Fig. 74 shows a schematic view of a progressive universal winding machine. The main shaft (1), is driven by an electric motor. At (2), we have the telescopic extension carrying the mandrel and held by an arm (3), which is affixed to the rack (4), in front of the machine. The rack is driven by the pinion gear (5), a crank and a friction clutch are provided to permit the rack to return to its starting position. The progression gears are shown

*Geo. Stevens Mfg. Co. model 125, model 225, U.S. Pat. No. 2,650,768

under (6), and the universal gears under (7). The cam which oscillates the shuttle mechanism is seen under (8), and the wire guide under (9).

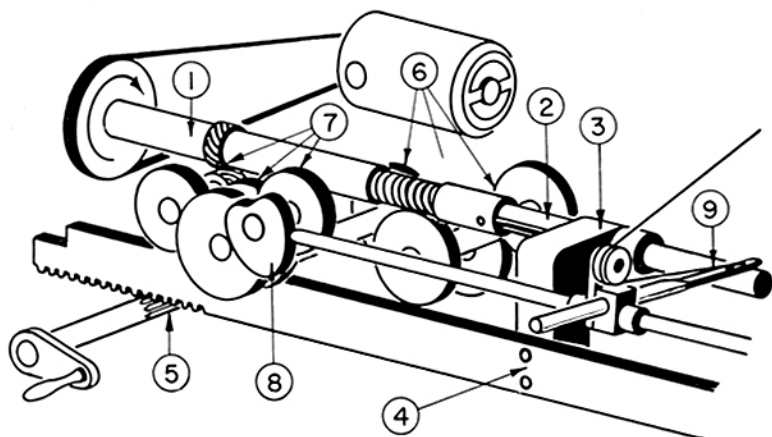

FIGURE 74—Mechanism of a progressive universal winding machine.

Counters, wire tensions, chucks, collets and arbors are similar to the ones previously described. The progressive universal winding machine can also be operated by a cam driven traverse bar instead of the rack drive. The advantage of the cam drive lies in its provision for winding progressive universal coils having a variable progression.

The wire guides are usually tilted (See Fig. 75) when winding progressive universal coils. Otherwise the adjustment is the same as for universal windings. Winding needles or winding fingers as shown in Fig. 47-A and Fig. 47-E are the recommended types of guides.



FIGURE 75—Tilted wire guide.

3. *GEOMETRY OF THE WINDING.* The progressive universal winding can be derived from the regular universal winding. Fig. 76 shows the wire position on the developed coil surface of

two consecutive turns. The illustrated winding has two crossovers per turn ($n = 2$) and a progressive layering. The use of the word *progressive* in connection with the coil layering describes the circumferential direction in which the layering proceeds. This should not be confused with the same word applied to describe the type of winding, where the application of the word refers to the axial advance of the winding.

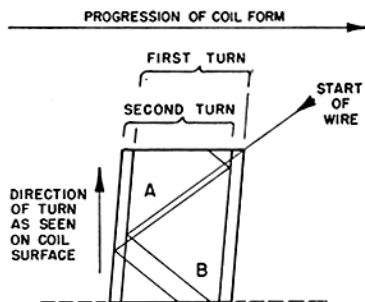

FIGURE 76—Basic geometry of a progressive universal winding, showing two turns of wire and featuring two crossovers per turn.

By comparing the strokes A and B in Fig. 76, it will be noted that the spacing between adjacent turns is closer in A and wider in B.

It will be remembered that the weaving action of the wire guide consists of forward and backward strokes parallel to the axial direction of progression. These strokes either aid or oppose the progression, thus causing the inequality of wire spacing between A and B.

As previously stated, during the discussion of the regular universal winding, the minimum center distance permissible between adjacent turns is 1.25δ , where δ is the total wire diameter including all insulation. This minimum distance must be maintained where the stroke of the wire guide is opposed by the travel of the coil form bringing the wires closer together.*

In general, it will be found that a gear ratio employed for the universal shuttle oscillation must provide a looser winding for the

*This pertains to progressive layering. Retrogressive layering will result in less space during the aiding stroke and in a wide space during the opposing stroke.

progressive universal winding than for the corresponding regular universal winding.

The formula to determine the ratio employed to wind a regular universal coil was found to be

$$r = 2/n(1 \pm 1.25\delta/qc)$$

where the (+) sign was taken for progressive and the (-) sign for retrogressive layering.

The progressive universal winding requires the circumferential advance per crossover and winding cycle to be increased to keep the wires apart during both strokes. The amount of increase as given by Dr. A. W. Simon is

$$e = p/nc$$

where n is the number of crossovers per turn, c is the cam size, and p is the pitch of the winding, expressing the axial advance of the coil form in inches per turn.

p is found to equal l/t , where t is the number of turns per inch.

The small value for e is added to the fraction which represents the circumferential advance during each winding cycle. Thus the formula to determine the gear ratio employed to actuate the shuttle while winding progressive universal coils is

$$r = 2/n [1 \pm (e + 1.25 \delta/qc)]$$

The formula, as it is represented, proved to be satisfactory, though Dr. Simon recommends a higher accuracy which can be obtained by solving for r as follows:

$$r = (2/n) [1 \pm e \pm \sqrt{a^2 + b^2} + a^2 - e^2]$$

where the parameters are given as

$$\begin{aligned} a &= s/qc \\ b &= ns/q \pi d \\ e &= p/nc \end{aligned}$$

All other symbols are equivalent to those used in the explanation of the regular universal winding.

4. WINDING PATTERNS. The number of crossovers per turn is mainly responsible for the appearance of the wound coil surface.

Three major variations can be observed. Coils having an even integer as the number of crossovers per turn will show the most

uniform pattern. Coils with a fractional number of crossovers per turn and those with an odd integer as the number of crossovers per turn do not always provide uniformity. Their appearance is often confusing. Since the choice of such patterns does not provide for electrical advantages, their construction should not be considered. By selecting a suitable cam size, a progressive universal coil can, in most cases, be designed to have an even integer number of crossovers per turn.

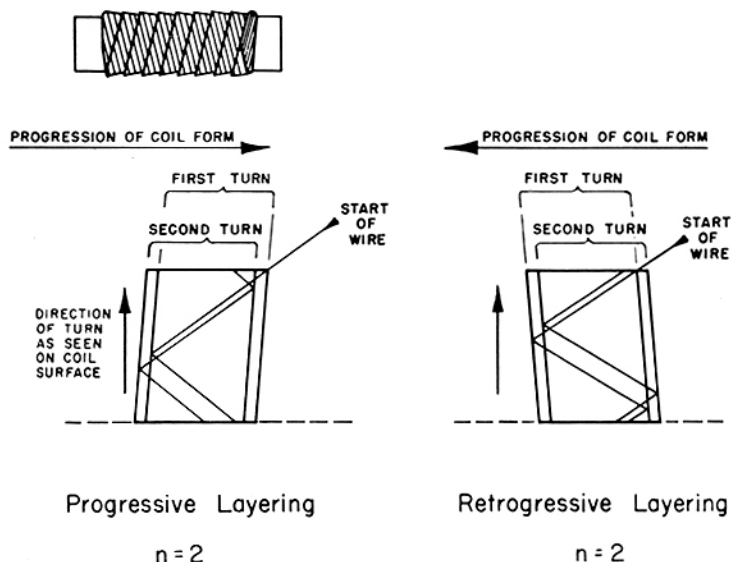

FIGURE 77—Left-hand ridge progressive universal coil and corresponding surface patterns.

A further modification in the appearance of a coil can be obtained by either using progressive or retrogressive layering. The direction in which the coil form moves during the winding procedure can be reversed. This results in a right hand or left hand ridge on the surface of the coil. The following Fig. 77 and 78 show four basic appearances, the geometry of which can be studied.

5. *THE PRACTICE OF CALCULATING THE GEAR RATIO.* In most cases the length of the winding l and the number of turns W are the fundamental data, together with the total wire diameter δ and the coil form diameter d

$$\frac{W \delta}{l}$$

will express the factor for overlapping, as mentioned at the beginning. If this factor is just a little smaller than two, it will guarantee the most stable and uniform winding. If the factor is equal or less than one, a single layer winding should be employed. If larger than three, the coil will take a rather ugly shape, and the regular universal winding might yield better results.

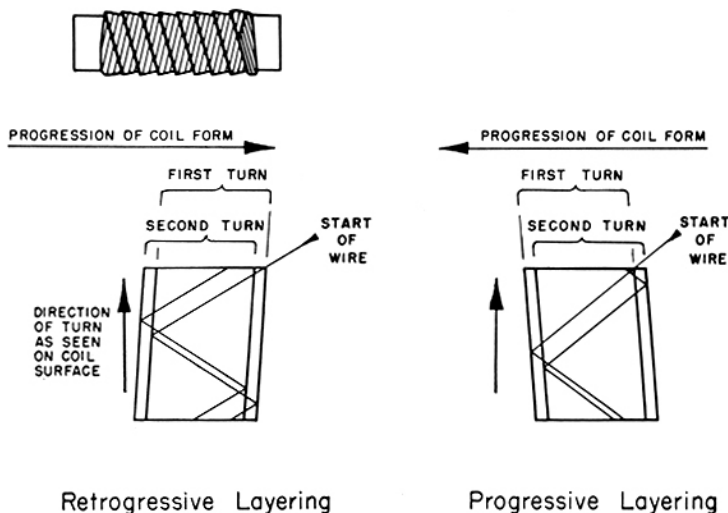

$n = 2$

$n = 2$

FIGURE 78—Right-hand ridge progressive universal coil and corresponding surface patterns.

The number of turns per inch t will be found from

$$t = \frac{W}{l}$$

and the ratio of the progression gears to be mounted into the rear of the machine results in:

$$r_b = \frac{t}{95.49} = \frac{z_n}{z_r}$$

Once a set of gears has been found for r , the exact pitch p must be determined:

$$p = \frac{z_r}{95.49 z_n}$$

At this point n , the number of crossovers per turn, should be chosen as a compromise between the universal cam and the form diameter. The alignment chart in Fig. 79 will be of great help. It also gives the value for q , the number of crossovers per winding cycle.

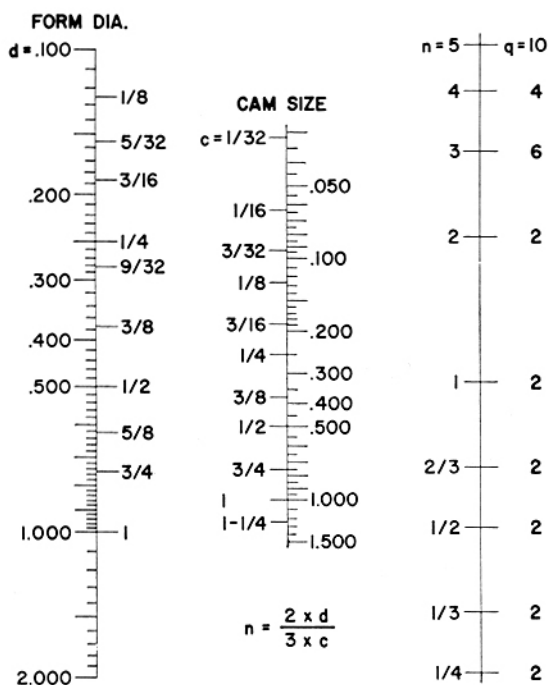

FIGURE 79—Alignment chart, to be used when choosing cam size and surface pattern. The surface pattern is characterized by its number of crossovers per turn n and its number of crossovers per winding cycle q . Always align slightly above or precisely at the chosen value for n , in order to maintain an angle of at least 78° between the wire and axis of the coil.

With the aid of these values, we will find r_u the universal gear ratio, according to:

$$r_u = 2/n[1 \pm (e + 1.25 \delta/qc)]$$

where e is found from:

$$e = p/nc$$

The gear train to suit r can be found in the previously described way by using a slide rule or the table of reciprocals.

6. *VARIABLE PITCH PROGRESSIVE UNIVERSAL WINDING.* Permeability tuned receiver equipment sometimes requires the use of high Q -coils whose inductance can be varied in a certain geometrical fashion by inserting an iron core.

The variable pitch progressive universal winding is often employed to wind such coils, whereby the progression of the coil is varied in such a manner, as to provide a certain characteristic of inductance versus core position.

The machine* employed in this type of winding resembles closely the previously described, progressive universal machine with the exception that the traverse bar is operated by a cam instead of a pinion gear. Fig. 87 illustrates the machine which can also be thought of as a combination of a universal winder and a cam driven machine.

All gears ratios can be calculated with the aid of formulae previously provided for the linear progressive universal winding, with the exception of the progression gear ratio r_b which can be found from

$$r_b = \frac{3.6 W}{\alpha}$$

where α is the degree of active cam rotation which corresponds to the cam excursion equivalent to the length of the winding, W is the number of turns per length.

The value for p , the progression (in inches per turn), should be selected to equal the largest pitch provided by the variable pitch cam. Since most cams of this type are shaped by hand, following a cut and try method, the value of p should be measured rather than calculated. It will be of help to refer to the section on linear and variable pitch cams, which contains more detailed information regarding cam design.

*Geo. Stevens Mfg. Co. models 125 AVP, 225 AVP

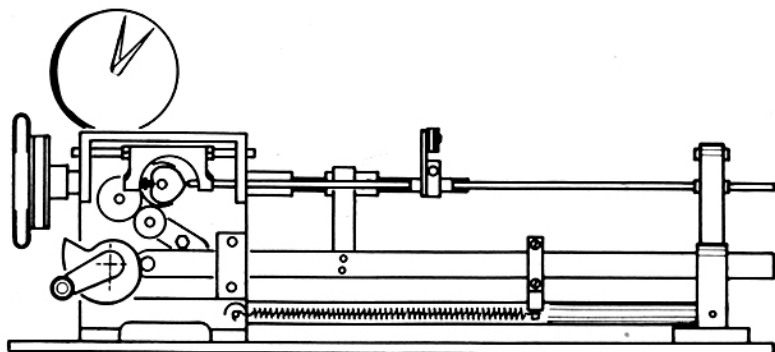

FIGURE 80—A variable pitch progressive universal winding machine.

The variable pitch progressive universal winding machine as shown in Fig 80 is probably the most versatile machine, since it can be used to wind all four types of winding described in the previous sections.

BIBLIOGRAPHY

- Simon, A. W....."Winding the Universal Coil."
Electronics, October, 1936.
- Joyner, A. A., and
Landon, V. D....."Theory and Design of Progressive
Universal Coils," *Communications*,
September, 1938.
- Hershey, L. M....."The Design of the Universal Winding,"
Proceedings I.R.E., August, 1941.
- Simon, A. W....."On the Winding of the Universal Coil,"
Proceedings I.R.E., January, 1945.
- Simon, A. W....."On the Theory of the Progressive
Universal Winding,"
Proceedings I.R.E., December, 1945.
- Simon, A. W....."Universal Coil Design,"
Radio, February-March, 1947.
- Kantor, M....."Theory and Design of Progressive and
Ordinary Universal Windings,"
Proceedings, I.R.E., December, 1947.
- Simon, A. W....."The Theory and Design of Progressive
and Ordinary Universal Windings,"
Proceedings I.R.E., September, 1949.
- Page, R. M....."1400 Gear Ratios,"
Copyright 1942, The Industrial Press,
148 Lafayette St., New York, N. Y.

APPENDIX

Symbols. The following symbols appear throughout the book:

- a, by definition, $a = s/qc$, also indicates spacing of "pi" coils.
- b, by definition, $b = ns/q\pi d$.
- c, cam size, measured in inches.
- d, dowel diameter, measured in inches.
- e, by definition, $e = p/nc$
- l, length of winding.
- n, number of crossovers per turn, pertaining to universal windings.
- p, pitch of winding, $p = l/t$.
- q, number of crossovers per winding cycle, pertaining to universal windings.
- r, gear ratio, ratio of the number of teeth on the driven gear to the number of teeth on the driver gear,
 $r_b = z_n/z_r$; $r_u = z_c/z_d$; $r_l = z_x/z_y$.
- s, center spacing of parallel wires, measured parallel to the coil axis.
- t, number of turns per inch, (tpi).
- w, circumferential distance covered during the winding of one winding cycle.
- x, universal progression or retrogression as measured along a coil edge. Expressed as a fraction of the coil circumference.
- y, circumferential distance covered during the winding from one crossover to the next.
- z, number of teeth for gear or rack,
 - z_c number of teeth on cam gear, universal mechanism,
 - z_d number of teeth on driver gear, universal mechanism,
 - z_n number of teeth on driven gear, progressive mechanism,
 - z_r number of teeth on driver gear, progressive mechanism,
 - z_x number of teeth on idler gear, meshing the driver gear,
 - z_y number of teeth on idler gear, meshing the driven or cam gear.
- N, number of spokes or spirals per coil circumference.

- P, inherent pitch of a winding machine; the pitch wound by a machine if a 1/1 gear train is inserted. For cam driven machines, P equals the inherent pitch of cam and machine combined. See text.
- T, number of turns per layer.
- V, number of turns of one section of a multisection coil.
- W, total number of turns of a reactor or coil.
- β , (betta) cam follower angle of climb.
- γ , (gamma) angle of active cam section.
- δ , (delta) total wire diameter including all insulation, measured in inches.
- π , (pi) equals 3.1416.

Abbreviations. The following abbreviations appear throughout the book:

- AWG, American Wire Gauge
- deg, degree, angular measure
- dia, diameter
- in., inch
- max, maximum
- min, minimum
- rpm, revolutions per minute
- tan, tangent
- tpi, turns per inch
- tpl, turns per layer

Glossary of Terms which are Common to the
Coil Winding Industry

- arbor, device for holding the coil form, which in most cases is a tube, to the main shaft of the winding machine.
- chuck, device for clamping a solid coil form to the main shaft of the winding machine, see Fig. 28 and Fig. 3.
- collet, function similar to the chuck. Precision clamping may be achieved by using a collet instead of a chuck, see Fig. 28 and Fig. 6.
- mandrel, a slightly tapered, round core upon which a coil is wound and slipped off after completion.
- pi-coil, coil or inductor consisting of two or more separately wound sections which are placed in parallel on one common coil form.
- bobbin, body with flanges on which wire is wound giving support to the coil, the bobbin being part of the finished coil.
- spool, usually a round cylinder with flanges. Supply wire is wound on a spool for storage.
- capstan, drum around which wire is placed to apply tension to the running wire. A brake attached to the drum controls the amount of tension.
- tension, force opposing the motion of the wire while being fed to the winding machine.
- shuttle, mechanism which causes and transfers a reciprocating motion. A shuttle of a universal winding machine consists of a cam, a yoke, a rod and a guide arm.

- idler gear assembly, usually two or more gears, meshing a driver and a driven gear. It changes the gear ratio of the driven to the driver gear by a factor significant to each set of idler gears.
- universal winding, type of winding in which the wires cross each other in a definite angle to the coil axis.
- progressive winding, type of winding in which the wires run parallel and at a right angle to the coil axis. Each subsequent turn follows parallel to the previous turn in the direction of the coil axis.
- progressive universal winding, type of winding where universally woven layers of wire are placed in a spiral around a coil form.
- tap, intermediate connection made between the ends of a coil.
- tab, terminal, indicator or marker.
- core, internal part of a coil between the axis and the winding; that part of a coil which carries the strongest concentration of electromagnetic flux.

GEAR CHARTS for SINGLE and MULTI
LAYER WINDINGS

The gear charts listed contain only a limited number of gear trains. The range of these charts was chosen on the basis of the most practical dimensions. The possible uses of winding machines go far beyond the range of the charts given.

CHART I, page 1.

GEAR CHART FOR CAM DRIVEN WINDING MACHINES.

Internal machine ratio 100:1; Using 180° cams
(heart shape) $r=t/P$; $P=50/c$; $r=T/50$; T =turns
per layer.

T	D'r	Id.	D'n	T	D'r	Id.	D'n	T	D'r	Id.	D'n
15	100	1/2	60	55	60	1/1	66	95	50	1/1	95
16	100	1/2	64	56	75	1/1	84	96	50	1/1	96
17	100	1/2	68	57	64	1/1	73	97	50	1/1	97
18	100	1/2	72	58	75	1/1	87	98	50	1/1	98
19	92	1/2	70	59	67	1/1	79	99	50	1/1	99
20	90	1/2	72	60	75	1/1	90	100	50	1/1	100
21	100	1/2	84	61	73	1/1	89	101	50	1/1	101
22	75	1/2	66	62	75	1/1	93	102	50	1/1	102
23	75	1/2	69	63	73	1/1	92	103	50	1/1	103
24	75	1/2	72	64	75	1/1	96	104	50	1/1	104
25	75	1/2	75	65	70	1/1	91	105	50	1/1	105
26	75	1/2	78	66	72	1/1	95	106	50	1/1	106
27	75	1/2	81	67	59	1/1	79	107	50	1/1	107
28	75	1/2	84	68	67	1/1	91	108	50	1/1	108
29	75	1/2	87	69	71	1/1	98	109	50	1/1	109
30	75	1/2	90	70	65	1/1	91	110	50	1/1	110
31	75	1/2	93	71	69	1/1	98	111	50	1/1	111
32	75	1/2	96	72	66	1/1	98	112	50	1/1	112
33	75	1/2	99	73	61	1/1	89	113	50	1/1	113
34	72	1/2	98	74	52	1/1	77	114	50	1/1	114
35	72	1/2	101	75	60	1/1	90	115	50	1/1	115
36	75	1/2	108	76	54	1/1	82	116	50	1/1	116
37	75	1/2	111	77	52	1/1	80	117	50	1/1	117
38	75	1/2	114	78	59	1/1	92	118	50	1/1	118
39	73	1/2	114	79	57	1/1	90	119	50	1/1	119
40	75	1/2	120	80	60	1/1	96	120	50	1/1	120
41	70	1/2	115	81	58	1/1	94	121	76	2/1	92
42	56	1/2	94	82	50	1/1	82	122	68	2/1	83
43	57	1/2	98	83	53	1/1	87	123	65	2/1	80
44	58	1/2	102	84	56	1/1	94	124	79	2/1	98
45	60	1/2	108	85	50	1/1	85	125	64	2/1	80
46	62	1/2	114	86	50	1/1	86	126	65	2/1	82
47	67	1/1	63	87	50	1/1	87	127	63	2/1	80
48	75	1/1	72	88	50	1/1	88	128	64	2/1	82
49	50	1/2	98	89	50	1/1	89	129	62	2/1	80
50	75	1/1	75	90	50	1/1	90	130	70	2/1	91
51	50	1/2	102	91	50	1/1	91	131	61	2/1	80
52	73	1/1	78	92	50	1/1	92	132	62	2/1	82
53	50	1/2	106	93	50	1/1	93	133	79	2/1	105
54	75	1/1	81	94	50	1/1	94	134	71	2/1	95

cont.

D'r Driver Gear; D'n Driven Gear; Id. Idler Ratio
Idler gear assemblies may consist of the following gears: 1/2=40/80; 1/1=60/60; 2/1=80/40;
4/1=120/30.

CHART I ,page 2.

T	D'r	Id.	D'n	T	D'r	Id.	D'n	T	D'r	Id.	D'n
135	80	2/1	108	218	50	2/1	109	332	35	2/1	116
136	75	2/1	102	220	50	2/1	110	336	33	2/1	111
137	65	2/1	89	222	50	2/1	111	340	35	2/1	119
138	58	2/1	80	224	50	2/1	112	344	32	2/1	110
139	72	2/1	100	226	50	2/1	113	348	33	2/1	115
140	75	2/1	105	228	50	2/1	114	352	34	2/1	120
141	71	2/1	100	230	50	2/1	115	356*	34	2/1	121
142	67	2/1	95	232	50	2/1	116	360*	36	2/1	130
143	70	2/1	100	234	50	2/1	117	364	33	2/1	120
144	66	2/1	95	236	50	2/1	118	368*	38	2/1	140
145	69	2/1	100	238	50	2/1	119	372	32	2/1	119
146	61	2/1	89	240	50	2/1	120	376*	34	2/1	128
147	68	2/1	100	242	43	2/1	104	380*	35	2/1	133
148	65	2/1	96	244	41	2/1	100	384	31	2/1	119
149	72	2/1	107	246	37	2/1	91	388*	36	2/1	140
150	70	2/1	105	248	42	2/1	104	392	25	2/1	98
152	56	2/1	85	250	40	2/1	100	396	25	2/1	99
154	65	2/1	100	252*	48	2/1	121	400	30	2/1	120
156	75	2/1	117	254	39	2/1	99	404	27	2/1	109
158	69	2/1	109	256	43	2/1	110	408	25	2/1	102
160	75	2/1	120	258	45	2/1	116	412	25	2/1	103
162	74	2/1	120	260	40	2/1	104	416	25	2/1	104
164	67	2/1	110	262	42	2/1	110	420	25	2/1	105
166	65	2/1	108	264*	47	2/1	124	424	25	2/1	106
168	66	2/1	111	266*	47	2/1	125	428	28	2/1	120
170	63	2/1	107	268*	47	2/1	126	432*	28	2/1	121
172	64	2/1	110	270	43	2/1	116	436	27	2/1	118
174	69	2/1	120	272*	46	2/1	125	440	27	2/1	119
176	54	2/1	95	274	42	2/1	115	444	27	2/1	120
178	59	2/1	105	276	38	2/1	105	448*	27	2/1	121
180	50	2/1	90	278	41	2/1	114	452	25	2/1	113
182	50	2/1	91	280	40	2/1	112	456	25	2/1	114
184	50	2/1	92	282	39	2/1	110	460	25	2/1	115
186	50	2/1	93	284	37	2/1	105	464	25	2/1	116
188	50	2/1	94	286	42	2/1	120	468*	26	2/1	122
190	50	2/1	95	288*	42	2/1	121	472	25	2/1	118
192	50	2/1	96	290	40	2/1	116	476	25	2/1	119
194	50	2/1	97	292	38	2/1	111	480	25	2/1	120
196	50	2/1	98	294*	46	2/1	135	484*	25	2/1	121
198	50	2/1	99	296*	44	2/1	130	488*	27	2/1	132
200	50	2/1	100	298*	42	2/1	125	492*	25	2/1	123
202	50	2/1	101	300	40	2/1	120	496*	25	2/1	124
204	50	2/1	102	304*	46	2/1	140	500*	25	2/1	125
206	50	2/1	103	308	39	2/1	120	504*	25	2/1	126
208	50	2/1	104	312*	40	2/1	125	508*	53	4/1	135
210	50	2/1	105	316	38	2/1	120	512*	50	4/1	128
212	50	2/1	106	320*	39	2/1	125	516*	50	4/1	129
214	50	2/1	107	324	37	2/1	120	520*	50	4/1	130
216	50	2/1	108	328	35	2/1	115	524*	50	4/1	131

cont.

*If diameter of gear should exceed size of gear box, as it may occur on some machines, search for other combination having the same ratio of $D'n / D'r$, thereby using idler specified.

CHART I ,page 3.

T	D'r	Id.	D'n	T	D'r	Id.	D'n	T	D'r	Id.	D'n
528*	50	4/1	132	620*	45	4/1	140	716*	38	4/1	136
532*	50	4/1	133	624*	40	4/1	125	720*	36	4/1	130
536*	50	4/1	134	628*	40	4/1	126	724*	35	4/1	127
540*	50	4/1	135	632*	43	4/1	136	728*	37	4/1	135
544*	48	4/1	131	640*	40	4/1	128	732*	36	4/1	132
548*	48	4/1	132	644*	40	4/1	129	736*	38	4/1	140
552*	50	4/1	138	648*	41	4/1	133	740*	35	4/1	130
556*	47	4/1	131	652*	40	4/1	130	744*	34	4/1	127
560*	45	4/1	126	656*	38	4/1	125	748*	36	4/1	135
564*	46	4/1	130	660*	39	4/1	129	752*	34	4/1	128
568*	45	4/1	128	664*	40	4/1	133	756*	37	4/1	140
572*	49	4/1	140	668*	38	4/1	127	760*	36	4/1	137
576*	48	4/1	138	672*	39	4/1	131	764*	34	4/1	130
580*	43	4/1	125	676*	39	4/1	132	768*	33	4/1	127
584*	44	4/1	129	680*	37	4/1	126	772*	35	4/1	135
588*	44	4/1	130	684*	37	4/1	127	776*	35	4/1	136
592*	46	4/1	136	688*	40	4/1	138	780*	32	4/1	125
596*	44	4/1	131	692*	37	4/1	128	784*	32	4/1	126
600*	45	4/1	135	696*	40	4/1	139	788*	33	4/1	130
604*	43	4/1	130	700*	40	4/1	140	792*	31	4/1	123
608*	43	4/1	131	704*	38	4/1	134	796*	34	4/1	135
612*	45	4/1	138	708*	38	4/1	135	800*	35	4/1	140
616*	45	4/1	139	712*	37	4/1	132	(* see previous page)			

GEAR CHART FOR SCREW TRAVERSE MACHINES.

CHART II ,page 1.

Internal machine ratio 20:1 ; Pitch of traverse screw 10 ;
 r t/200 ; t turns per inch ;for close wound coils t 1/ .

t	D'r	Id.	D'n	t	D'r	Id.	D'n	t	D'r	Id.	D'n
60	100	1/2	60	100	100	1/2	100	140	100	1/1	70
61	100	1/2	61	101	100	1/2	101	141	105	1/1	74
62	100	1/2	62	102	100	1/2	102	142	100	1/1	71
63	100	1/2	63	103	100	1/2	103	143	112	1/1	80
64	100	1/2	64	104	100	1/2	104	144	100	1/1	72
65	100	1/2	65	105	100	1/2	105	145	105	1/1	76
66	100	1/2	66	106	100	1/2	106	146	100	1/1	73
67	100	1/2	67	107	100	1/2	107	147	102	1/1	75
68	100	1/2	68	108	100	1/2	108	148	100	1/1	74
69	100	1/2	69	109	100	1/2	109	149	94	1/1	70
70	100	1/2	70	110	100	1/2	110	150	100	1/1	75
71	100	1/2	71	111	110	1/1	61	151	98	1/1	74
72	100	1/2	72	112	100	1/1	56	152	100	1/1	76
73	100	1/2	73	113	115	1/1	65	153	98	1/1	75
74	100	1/2	74	114	100	1/1	57	154	100	1/1	77
75	100	1/2	75	115	120	1/1	69	155	98	1/1	76
76	100	1/2	76	116	100	1/1	58	156	100	1/1	78
77	100	1/2	77	117	106	1/1	62	157	93	1/1	73
78	100	1/2	78	118	100	1/1	59	158	100	1/1	79
79	100	1/2	79	119	116	1/1	69	159	88	1/1	70
80	100	1/2	80	120	100	1/1	60	160	100	1/1	80
81	100	1/2	81	121	119	1/1	72	161	92	1/1	74
82	100	1/2	82	122	100	1/1	61	162	100	1/1	81
83	100	1/2	83	123	117	1/1	72	163	92	1/1	75
84	100	1/2	84	124	100	1/1	62	164	100	1/1	82
85	100	1/2	85	125	104	1/1	65	165	97	1/1	80
86	100	1/2	86	126	100	1/1	63	166	100	1/1	83
87	100	1/2	87	127	104	1/1	66	167	91	1/1	76
88	100	1/2	88	128	100	1/1	64	168	100	1/1	84
89	100	1/2	89	129	110	1/1	71	169	90	1/1	76
90	100	1/2	90	130	100	1/1	65	170	100	1/1	85
91	100	1/2	91	131	110	1/1	72	171	83	1/1	71
92	100	1/2	92	132	100	1/1	66	172	100	1/1	86
93	100	1/2	93	133	110	1/1	73	173	82	1/1	71
94	100	1/2	94	134	100	1/1	67	174	100	1/1	87
95	100	1/2	95	135	111	1/1	75	175	80	1/1	70
96	100	1/2	96	136	100	1/1	68	176	100	1/1	88
97	100	1/2	97	137	108	1/1	74	177	95	1/1	84
98	100	1/2	98	138	100	1/1	69	178	100	1/1	89
99	100	1/2	99	139	108	1/1	75	179	85	1/1	76

cont.

D'r Driver Gear ; D'n Driven Gear ; Id. Idler Ratio .
 Idler gear assemblies may consist of the following gears :
 1/2 40/80 or 30/60 ; 1/1 60/60 ; 2/1 80/40 or 60/30.

CHART II ,page 2.

t	D'r	Id.	D'n	t	D'r	Id.	D'n	t	D'r	Id.	D'n
180	100	1/1	90	258	93	1/1	120	354	61	1/1	108
181	84	1/1	76	260	70	1/1	91	356	59	1/1	105
182	100	1/1	91	262	71	1/1	93	358	62	1/1	111
183	82	1/1	75	264	72	1/1	95	360	60	1/1	108
184	100	1/1	92	266	79	1/1	105	362	58	1/1	105
185	80	1/1	74	268	56	1/1	75	364	56	1/1	102
186	100	1/1	93	270	63	1/1	85	366	59	1/1	108
187	77	1/1	72	272	75	1/1	102	368	57	1/1	105
188	100	1/1	94	274	65	1/1	89	370	54	1/1	100
189	73	1/1	69	276	58	1/1	80	372	58	1/1	108
190	100	1/1	95	278	72	1/1	100	374	62	1/1	116
191	67	1/1	64	280	75	1/1	105	376	59	1/1	111
192	100	1/1	96	282	66	1/1	93	378	56	1/1	106
193	85	1/1	82	284	62	1/1	88	380	60	1/1	114
194	100	1/1	97	286	72	1/1	103	382	56	1/1	107
195	82	1/1	80	288	75	1/1	108	384	52	1/1	100
196	100	1/1	98	290	60	1/1	87	386	57	1/1	110
197	67	1/1	66	292	74	1/1	108	388	52	1/1	101
198	100	1/1	99	294	68	1/1	100	390	60	1/1	117
200	100	1/1	100	296	75	1/1	111	392	50	1/1	98
202	100	1/1	101	298	55	1/1	82	394	65	2/1	66
204	100	1/1	102	300	70	1/1	105	396	94	2/1	95
206	100	1/1	103	302	57	1/1	86	400	50	1/1	100
208	100	1/1	104	304	50	1/1	76	404	46	1/1	93
210	100	1/1	105	306	68	1/1	104	408	48	1/1	98
212	100	1/1	106	308	74	1/1	114	412	49	1/1	101
214	100	1/1	107	310	60	1/1	93	416	49	1/1	102
216	100	1/1	108	312	59	1/1	92	420	50	1/1	105
218	100	1/1	109	314	72	1/1	113	424	65	2/1	69
220	100	1/1	110	316	62	1/1	98	428	84	2/1	90
222	100	1/1	111	318	63	1/1	100	432	75	2/1	81
224	100	1/1	112	320	50	1/1	80	436	78	2/1	85
226	100	1/1	113	322	51	1/1	82	440	80	2/1	88
228	100	1/1	114	324	55	1/1	89	444	72	2/1	80
230	100	1/1	115	326	51	1/1	83	448	66	2/1	74
232	100	1/1	116	328	50	1/1	82	452	77	2/1	87
234	100	1/1	117	330	57	1/1	94	456	71	2/1	81
236	100	1/1	118	332	70	1/1	116	460	53	2/1	61
238	100	1/1	119	334	64	1/1	107	464	56	2/1	65
240	100	1/1	120	336	63	1/1	106	468	53	2/1	62
242	96	1/1	116	338	65	1/1	110	472	61	2/1	72
244	82	1/1	100	340	60	1/1	102	476	68	2/1	81
246	87	1/1	107	342	55	1/1	94	480	50	2/1	60
248	79	1/1	98	344	61	1/1	105	484	62	2/1	75
250	80	1/1	100	346	52	1/1	90	488	68	2/1	83
252	85	1/1	107	348	54	1/1	94	492	65	2/1	80
254	89	1/1	113	350	60	1/1	105	496	54	2/1	67
256	86	1/1	110	352	54	1/1	95	500	80	2/1	100

CHART III, page 1.

WIRE CHART for BARE and COATED COPPER WIRE

Size AWG No	Diameter bare, nom. inches	Resistance Ohms per 1000 Ft. at 20° C	Diameter Plain Enamel		Diameter Heavy Enamel		Diameter Single Formvar		Diameter Heavy Formvar	
			min. inches	max. inches	min. inches	max. inches	min. inches	max. inches	min. inches	max. inches
10	.1019	.9989	.1024	.1054	.1040	.1071	.1024	.1054	.1040	.1071
11	.0907	1.260	.0913	.0942	.0928	.0958	.0913	.0943	.0928	.0958
12	.0808	1.588	.0814	.0840	.0829	.0855	.0814	.0840	.0829	.0855
13	.0720	2.003	.0726	.0750	.0740	.0765	.0726	.0750	.0740	.0765
14	.0641	2.525	.0648	.0670	.0661	.0684	.0648	.0670	.0661	.0684
15	.0571	3.184	.0578	.0598	.0591	.0612	.0578	.0598	.0591	.0612
16	.0508	4.016	.0515	.0534	.0529	.0548	.0515	.0534	.0529	.0548
17	.0453	5.064	.0460	.0477	.0473	.0491	.0460	.0477	.0473	.0491
18	.0403	6.385	.0410	.0426	.0423	.0440	.0410	.0426	.0423	.0440
19	.0359	8.051	.0366	.0382	.0378	.0395	.0366	.0382	.0378	.0395
20	.0320	10.15	.0326	.0341	.0338	.0353	.0326	.0341	.0338	.0353
21	.0285	12.80	.0292	.0305	.0303	.0316	.0292	.0305	.0303	.0316
22	.0254	16.14	.0261	.0273	.0271	.0284	.0261	.0273	.0271	.0284
23	.0226	20.36	.0232	.0244	.0242	.0255	.0232	.0244	.0242	.0255
24	.0201	25.67	.0208	.0218	.0218	.0229	.0208	.0218	.0218	.0229
25	.0179	32.37	.0186	.0195	.0195	.0206	.0186	.0195	.0195	.0206
26	.0159	40.81	.0166	.0174	.0175	.0185	.0166	.0174	.0175	.0185
27	.0142	51.47	.0149	.0156	.0157	.0165	.0149	.0156	.0157	.0165
28	.0126	64.90	.0132	.0140	.0140	.0149	.0132	.0140	.0140	.0149
29	.0113	81.83	.0119	.0126	.0126	.0134	.0119	.0126	.0126	.0134
30	.0100	103.2	.0105	.0112	.0112	.0120	.0105	.0112	.0112	.0120
31	.0089	130.1	.0094	.0100	.0101	.0108	.0094	.0101	.0101	.0108
32	.0080	164.1	.0085	.0091	.0091	.0098	.0085	.0091	.0091	.0098
33	.0071	206.9	.0075	.0081	.0081	.0088	.0075	.0081	.0081	.0088
34	.0063	260.9	.0067	.0072	.0072	.0078	.0067	.0073	.0072	.0078

contin.

CHART III, page 2.

Size AWG No	Diameter bare, nom. inches	Resistance Ohms per 1000 Ft. at 20° C	Diameter Plain Enamel		Diameter Heavy Enamel		Diameter Single Formvar		Diameter Heavy Formvar	
			min. inches	max. inches	min. inches	max. inches	min. inches	max. inches	min. inches	max. inches
35	.0056	329.0	.0059	.0064	.0064	.0070	.0060	.0065	.0064	.0070
36	.0050	414.8	.0053	.0058	.0057	.0063	.0054	.0059	.0057	.0063
37	.0045	523.1	.0047	.0052	.0052	.0057	.0049	.0053	.0052	.0057
38	.0040	659.6	.0042	.0047	.0046	.0051	.0043	.0047	.0046	.0051
39	.0035	831.8	.0036	.0041	.0040	.0045	.0038	.0042	.0040	.0045
40	.0031	1049.	.0032	.0037	.0036	.0040	.0034	.0038	.0036	.0040
41	.0028	1323.	.0029	.0033	.0032	.0036				
42	.0025	1669.	.0026	.0030	.0028	.0032				
43	.0022	2104.	.0023	.0026	.0026	.0030				
44	.0020	2654.	.0021	.0024	.0024	.0028				

Courtesy, REA Magnet Wire Company, Inc., Fort Wayne, Indiana.

USE of ALIGNMENT CHARTS for CALCULATING
UNIVERSAL GEAR RATIOS

The calculation of gear ratios is done
in two steps:

First, the form diameter d , and the cam size c , must be established. With these values, the number of crossovers per turn n , is determined by using the alignment chart for

$$n = 2d/3c$$

Find established values for d and c on corresponding scales. Place a straight edge (piece of wire or edge of paper) across chart, so that it intercepts both values. The extension of this line on the third scale will indicate the desired value for n , the number of crossovers per turn. If the answer is found to be between two numbered points of the scale, select the lower of the two numbers.

Secondly, a separate chart is given for each number of crossovers per turn. These charts are labeled by the specific number of crossovers per turn n . The value for δ , must be measured. Find measured value for δ , and establish value for c , on corresponding scales and align charts as previously described. The resultant value will be r , the gear ratio.

A limited selection of gear trains is provided parallel to the scale for r . Suggested gear trains can be used to wind universal coils. The advanced coil designer may choose his own gear trains using the table of reciprocals.

If the proper gear ratio falls in between two listed gear trains, use gear train above line of interception.

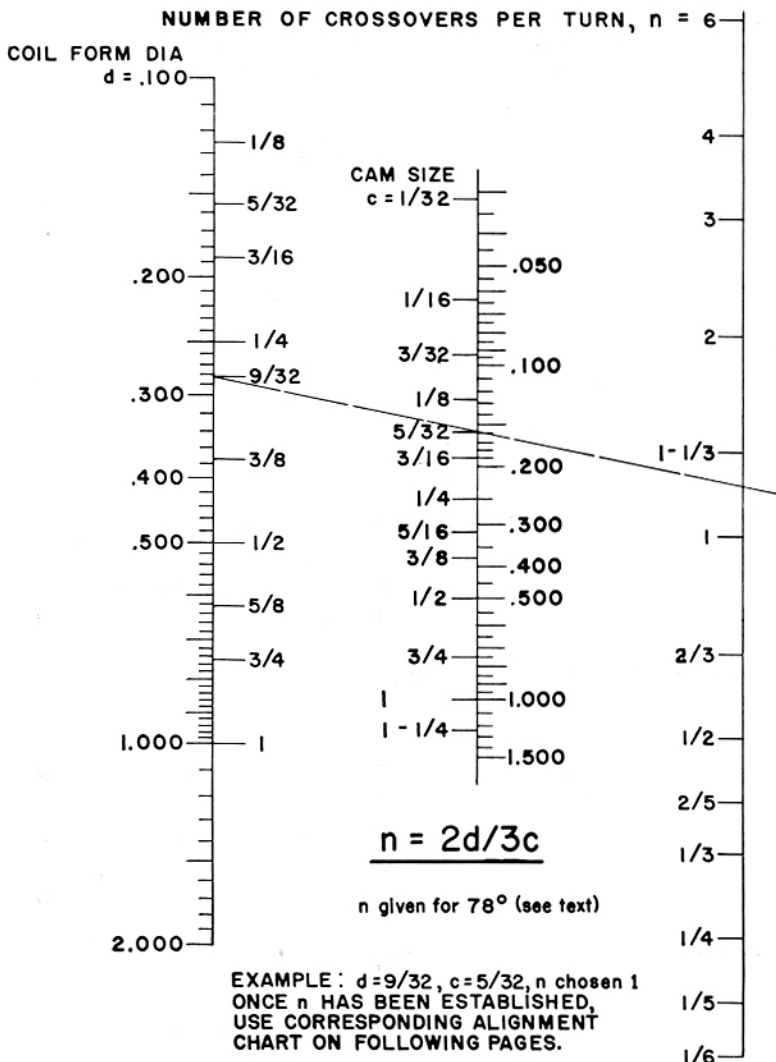

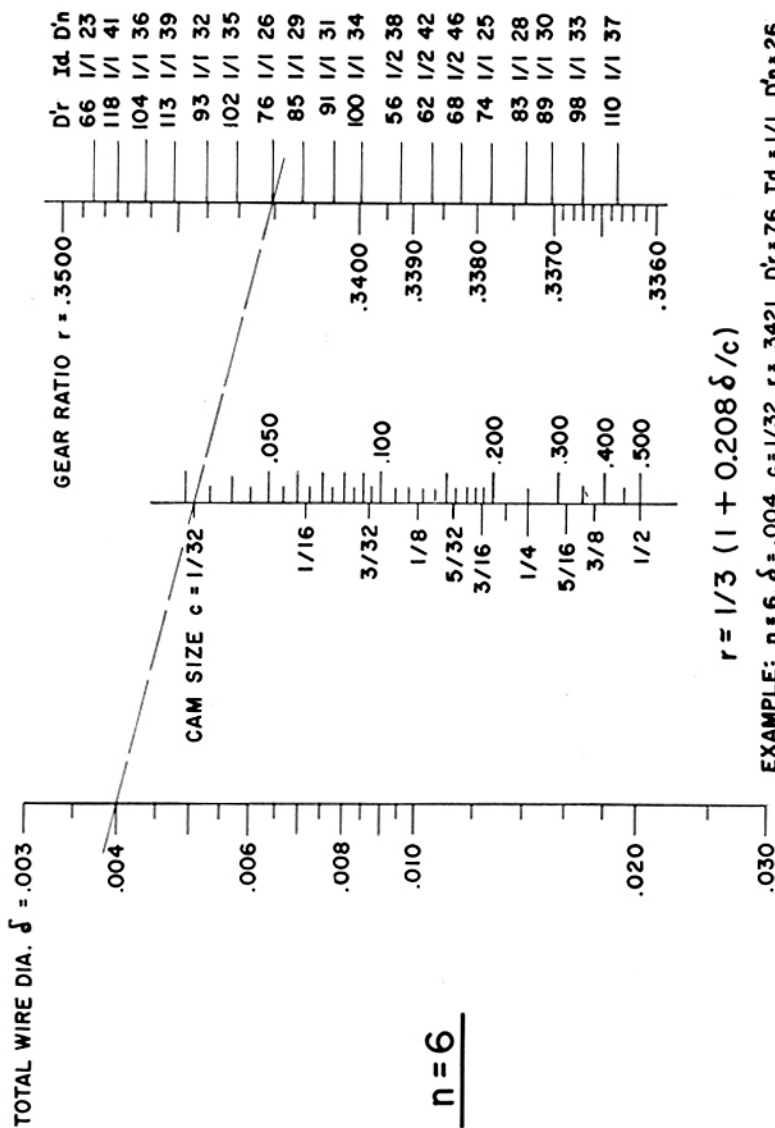

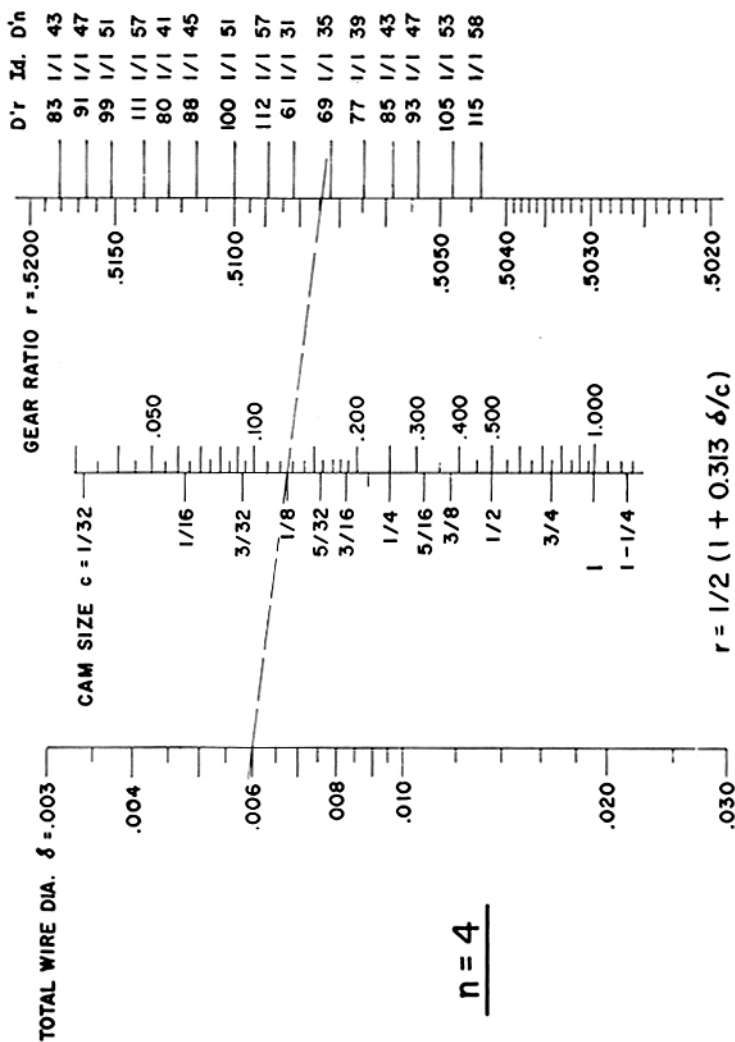

EXAMPLE: $n = 4$, $\delta = .006$, $c = 1/8$, $r = .5075$, $D'r = 69$, $Id = 1/1$, $D'n = 35$

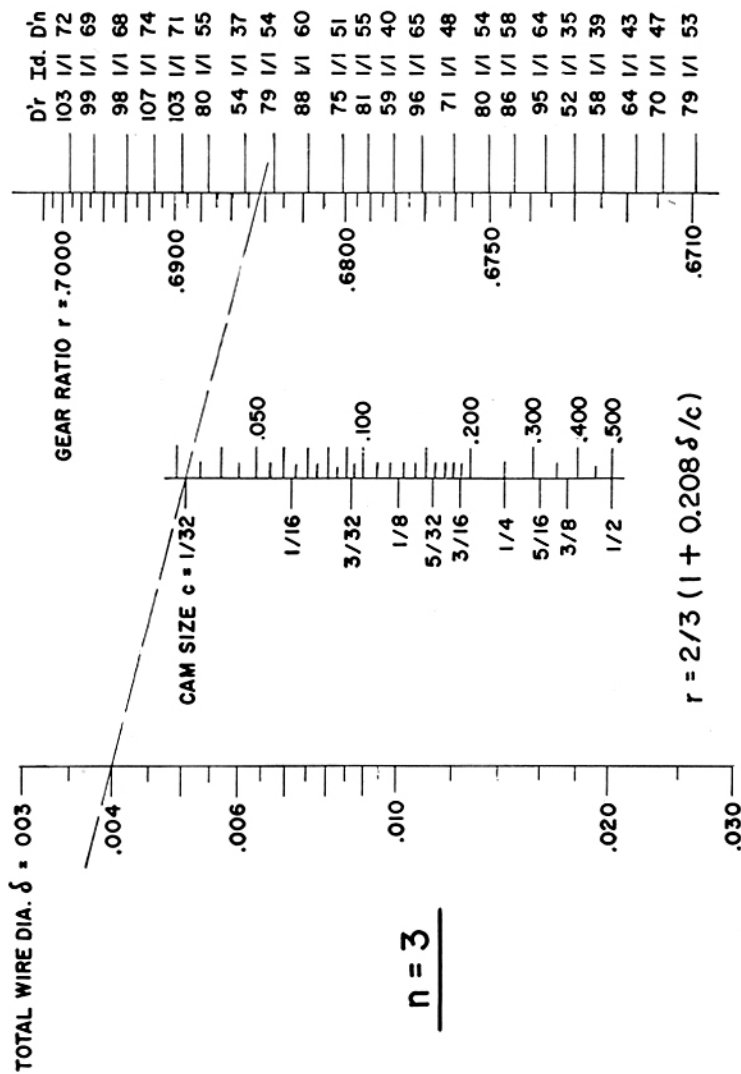

EXAMPLE: $n = 3, \delta = .004, c = 1/32, r = .6844, D'r = 79, Id. = 1/1, D'n = 54$

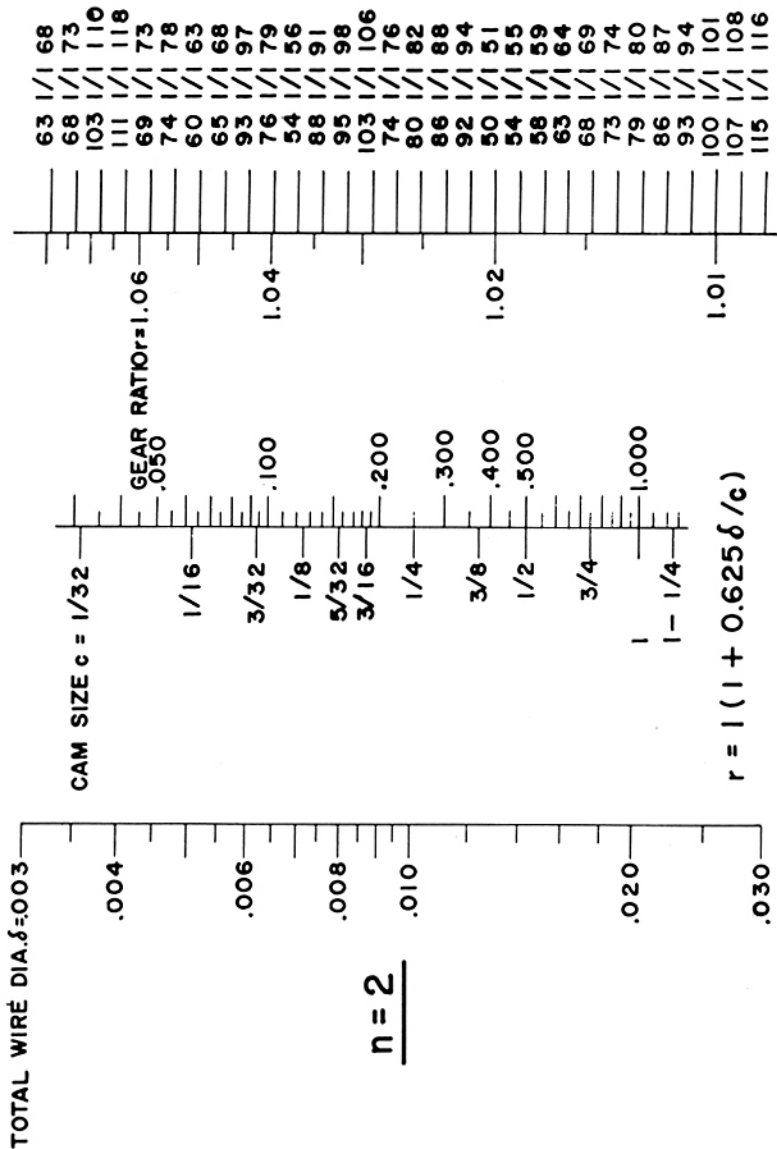

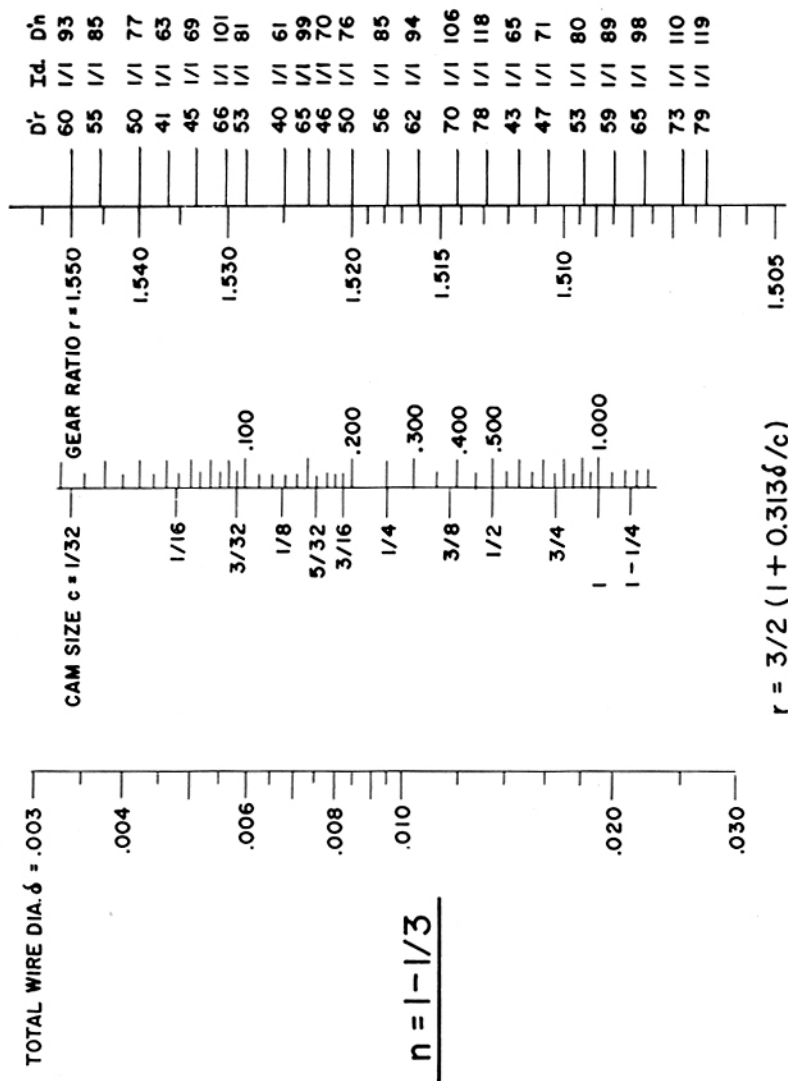

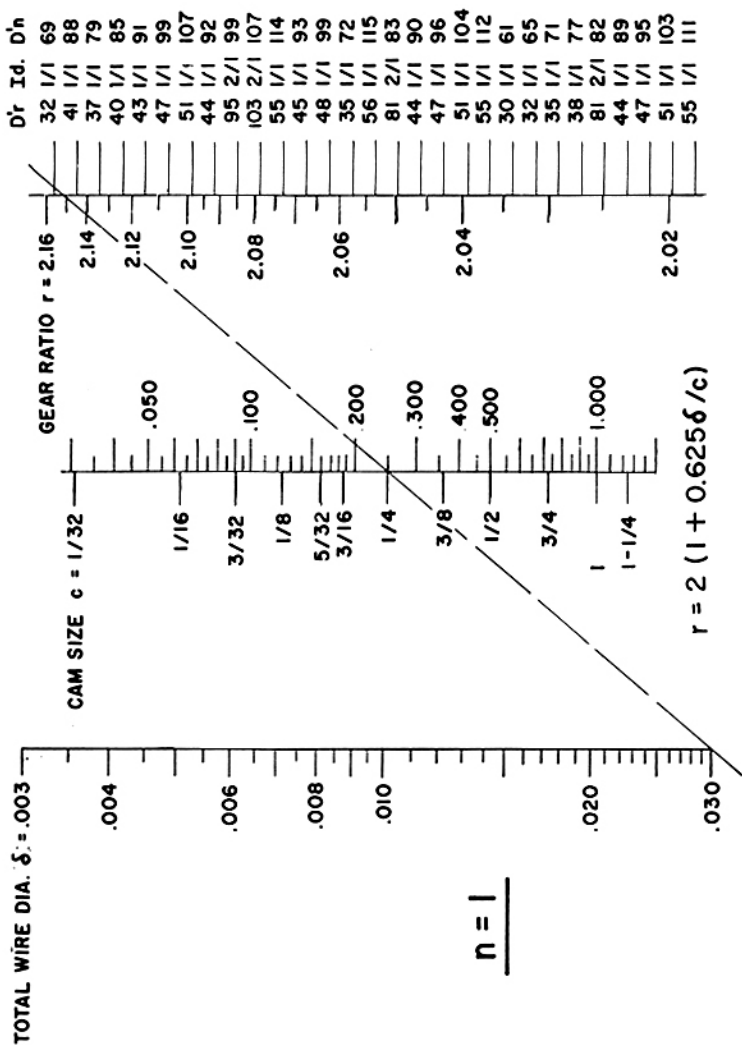

EXAMPLE: $n = 1, \delta = .030, c = 1/4, r = 2.15, D'r = 41, Id = 1/1, D'h = 88$

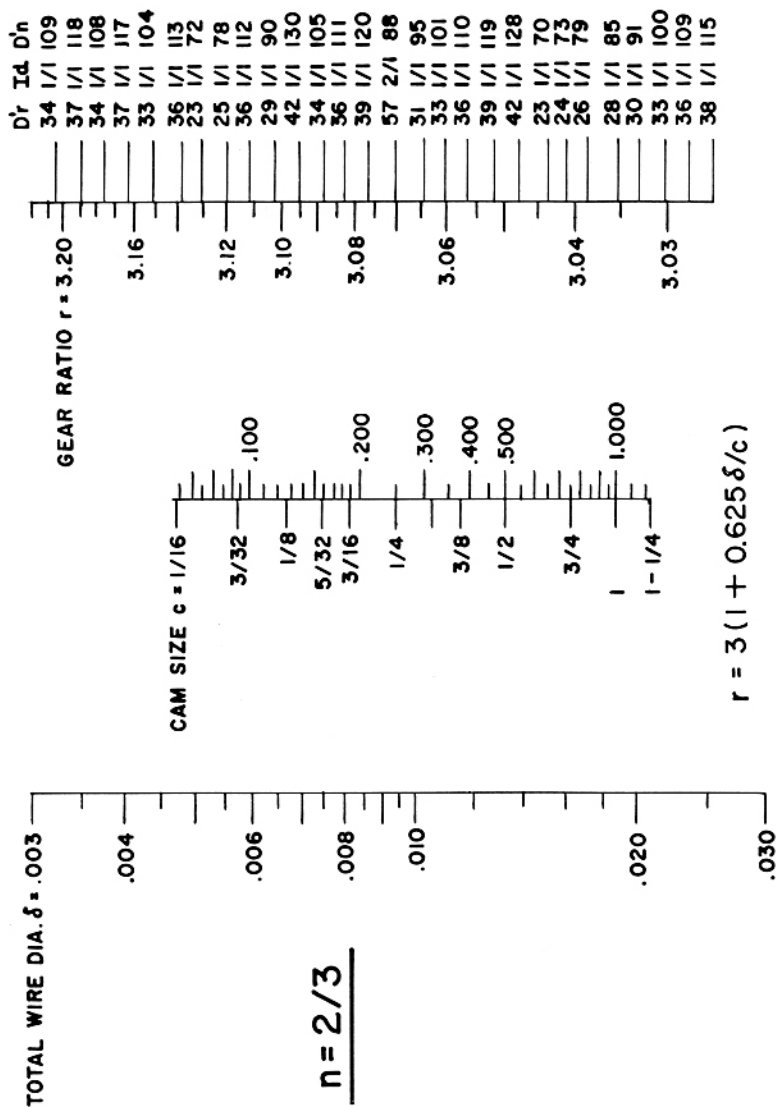

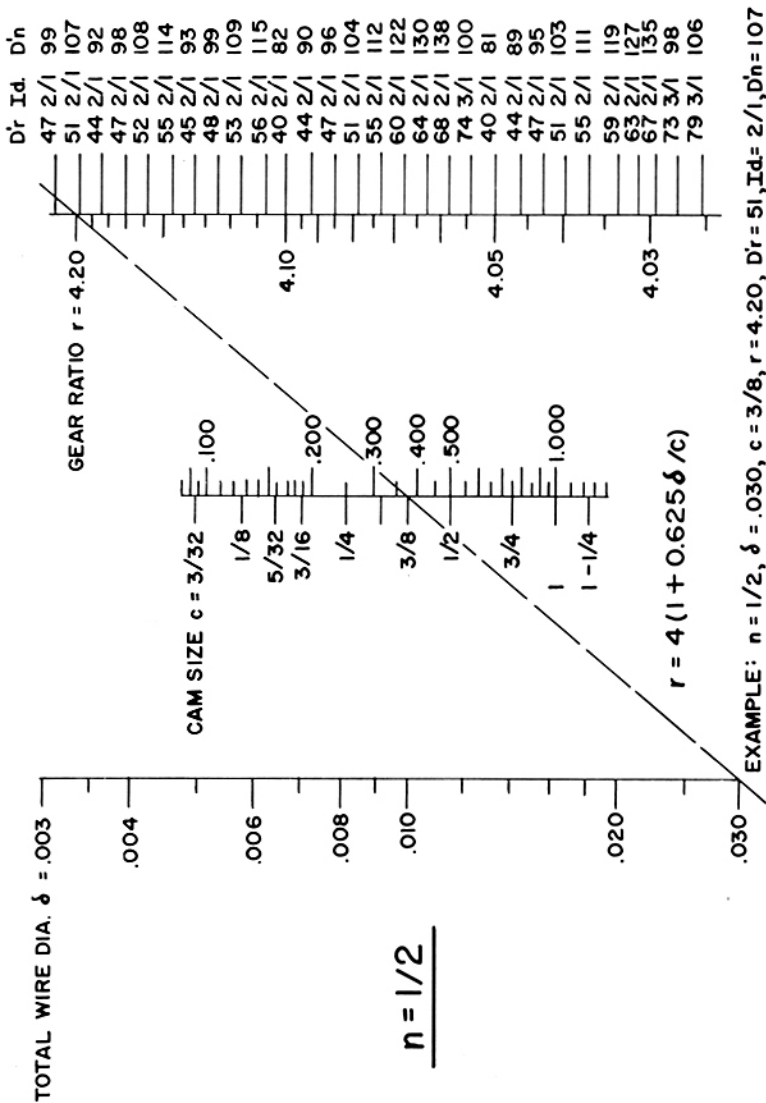

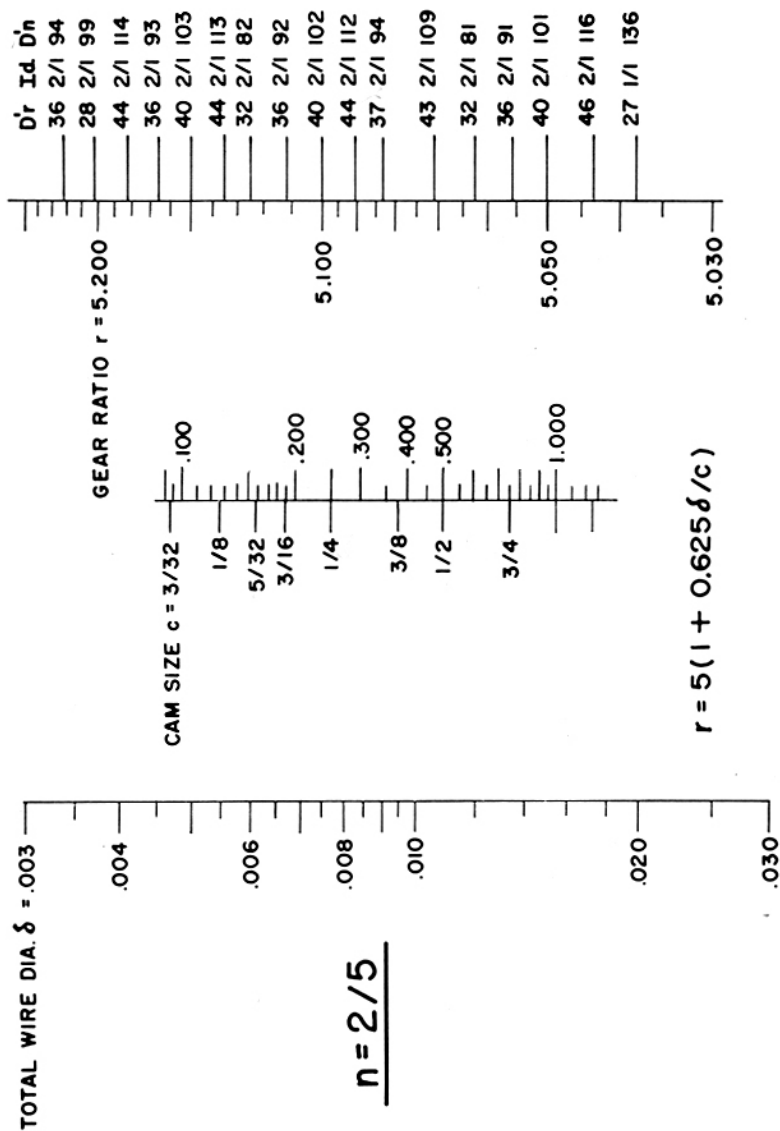

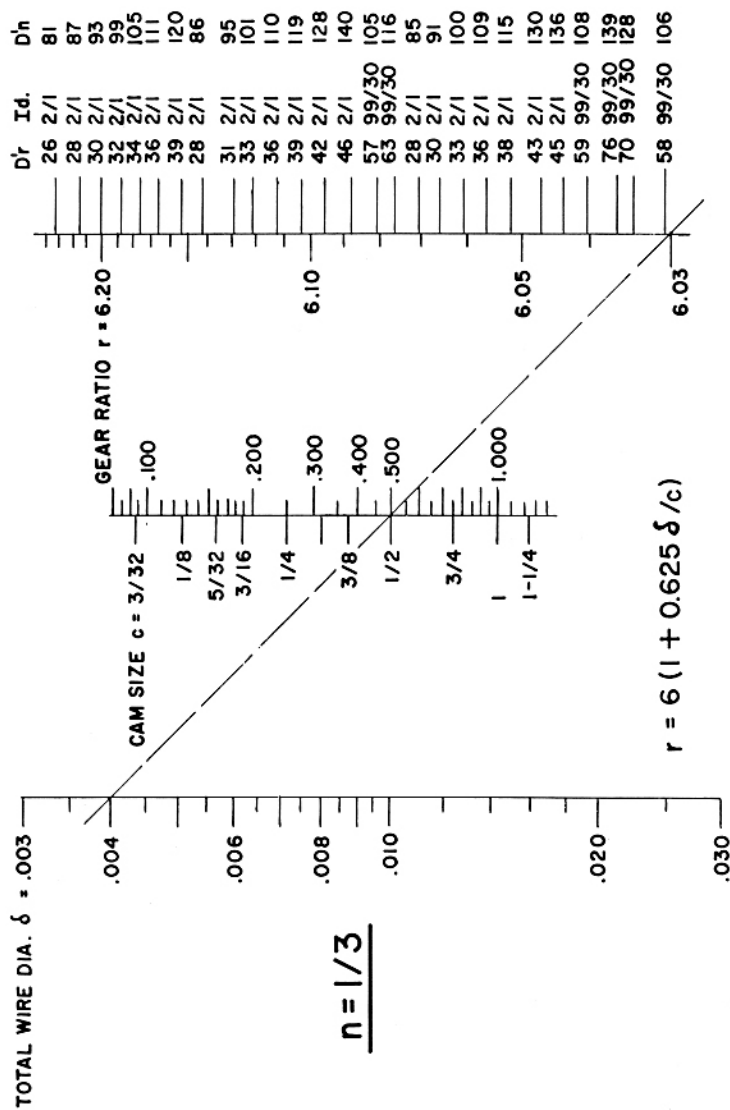

EXAMPLE: $n = 1/3, \delta = .004, c = 1/2, r = 6.03, Dh = 58, Id = 99/30, Dh = 106$

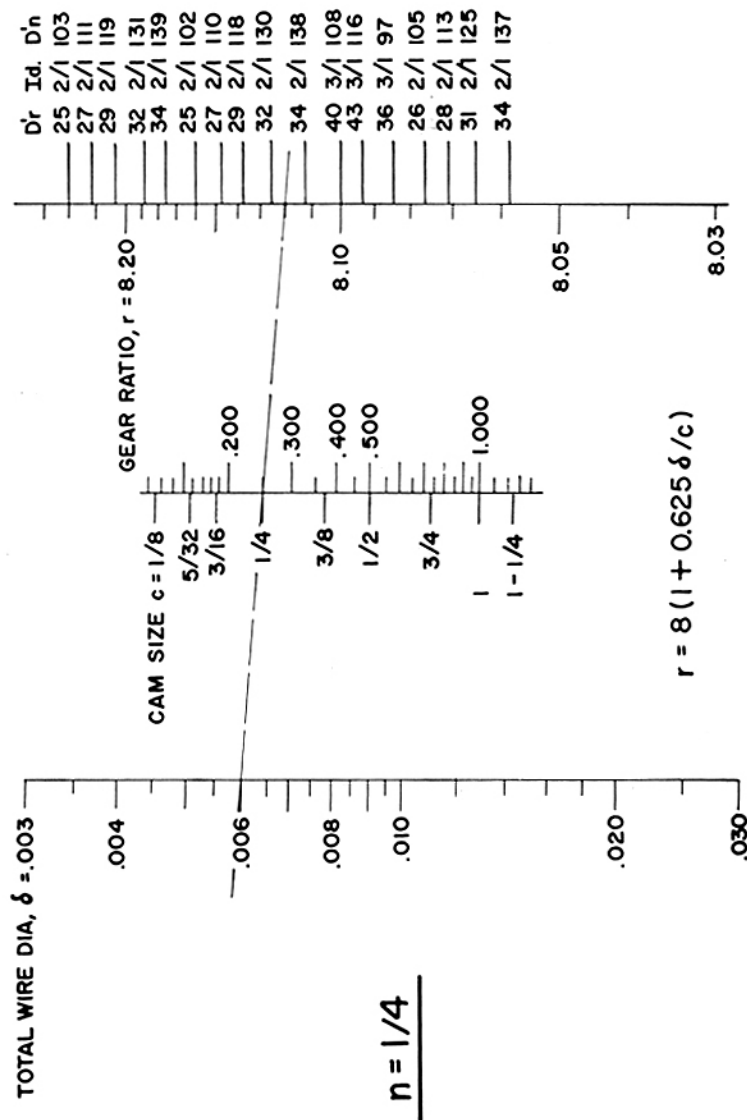

EXAMPLE: $n = 1/4, \delta = .006, c = 1/4, r = 8.12, D'r = 34, Id = 2/1, D'n = 38$

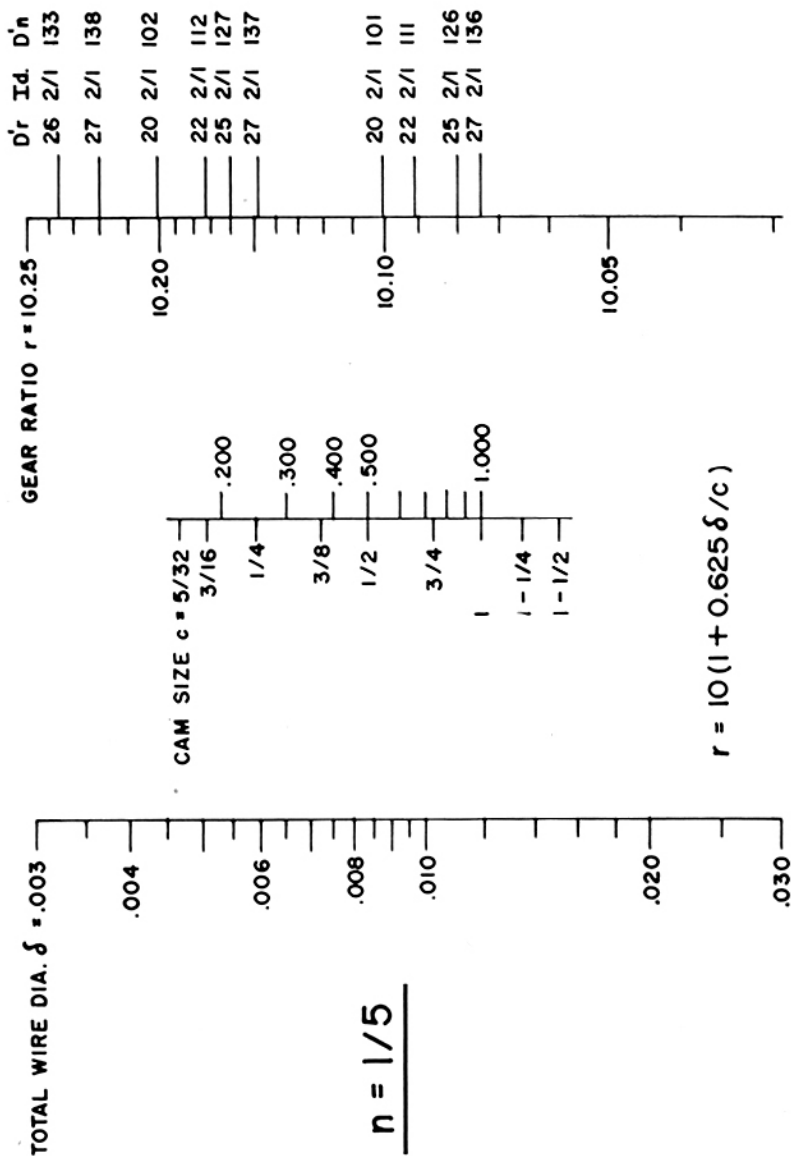

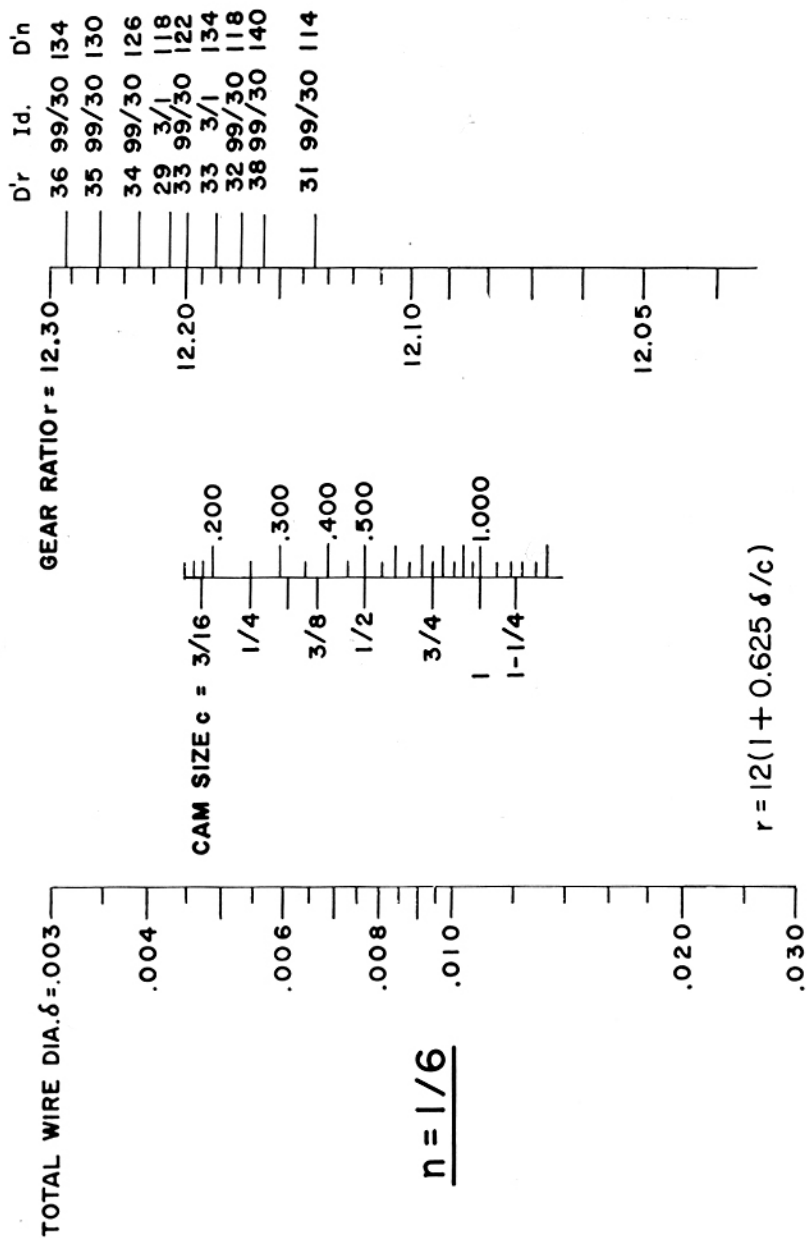

TABLE OF RECIPROALS

CHART V , page 1 .

x	1/x	2/x	3/x	4/x	5/x
20	.050 000	.100 000	.150 000	.200 000	.250 000
21	.047 619	.095 238	.142 857	.190 476	.238 095
22	.045 455	.090 909	.136 364	.181 818	.227 273
23	.043 478	.086 956	.130 435	.173 913	.217 391
24	.041 666	.083 333	.125 000	.166 666	.208 333
25	.040 000	.080 000	.120 000	.160 000	.200 000
26	.038 462	.076 923	.115 385	.153 846	.192 308
27	.037 037	.074 074	.111 111	.148 148	.185 185
28	.035 714	.071 429	.107 143	.142 857	.178 571
29	.034 483	.068 966	.103 448	.137 931	.172 413
30	.033 333	.066 667	.100 000	.133 333	.166 667
31	.032 258	.064 516	.096 774	.129 032	.161 290
32	.031 250	.062 500	.093 750	.125 000	.156 250
33	.030 303	.060 606	.090 909	.121 212	.151 515
34	.029 412	.058 824	.088 235	.117 647	.147 059
35	.028 571	.057 143	.085 714	.114 286	.142 857
36	.027 778	.055 555	.083 333	.111 111	.138 889
37	.027 027	.054 054	.081 081	.108 108	.135 135
38	.026 316	.052 632	.078 947	.105 263	.131 579
39	.025 641	.051 282	.076 923	.102 564	.128 205
40	.025 000	.050 000	.075 000	.100 000	.125 000
41	.024 390	.048 780	.073 171	.097 561	.121 951
42	.023 810	.047 619	.071 429	.095 238	.119 048
43	.023 256	.046 512	.069 767	.093 023	.116 279
44	.022 727	.045 455	.068 182	.090 909	.113 636
45	.022 222	.044 444	.066 666	.088 888	.111 111
46	.021 739	.043 478	.065 217	.086 957	.108 696
47	.021 277	.042 553	.063 830	.085 106	.106 383
48	.020 833	.041 667	.062 500	.083 333	.104 166
49	.020 408	.040 816	.061 224	.081 633	.102 041
50	.020 000	.040 000	.060 000	.080 000	.100 000
51	.091 608	.039 216	.058 824	.078 431	.098 039
52	.019 230	.038 462	.057 692	.076 923	.096 154
53	.018 868	.037 736	.056 604	.075 472	.094 340
54	.018 519	.037 037	.055 555	.074 074	.092 592
55	.018 182	.036 364	.054 545	.072 727	.090 909
56	.017 857	.035 714	.053 571	.071 429	.089 286
57	.017 544	.035 088	.052 632	.070 175	.087 719
58	.017 241	.034 483	.051 724	.068 966	.086 207
59	.016 949	.033 898	.050 847	.067 797	.084 746

contin.

CHART V , page 2 .

x	6/x	7/x	8/x	9/x	10/x
20	.300 000	.350 000	.400 000	.450 000	.500 000
21	.285 714	.333 333	.380 952	.428 571	.476 190
22	.272 727	.318 182	.363 636	.409 091	.454 545
23	.260 870	.304 348	.347 826	.391 304	.434 783
24	.250 000	.291 667	.333 333	.375 000	.416 667
25	.240 000	.280 000	.320 000	.360 000	.400 000
26	.230 769	.269 231	.307 692	.346 154	.384 615
27	.222 222	.259 259	.296 296	.333 333	.370 370
28	.214 286	.250 000	.285 714	.321 429	.357 143
29	.206 897	.241 379	.275 862	.310 345	.344 828
30	.200 000	.233 333	.266 667	.300 000	.333 333
31	.193 548	.225 806	.258 065	.290 323	.322 581
32	.187 500	.218 750	.250 000	.281 250	.312 500
33	.181 818	.212 121	.242 424	.272 727	.303 030
34	.176 471	.205 882	.235 294	.264 706	.294 118
35	.171 429	.200 000	.228 571	.257 143	.285 714
36	.166 667	.194 444	.222 222	.250 000	.277 778
37	.162 162	.189 189	.216 216	.243 243	.270 270
38	.157 895	.184 211	.210 526	.236 842	.263 158
39	.153 846	.179 487	.205 128	.230 769	.256 410
40	.150 000	.175 000	.200 000	.225 000	.250 000
41	.146 341	.170 732	.195 122	.219 512	.243 902
42	.142 857	.166 667	.190 476	.214 286	.238 095
43	.139 535	.162 791	.186 047	.209 302	.232 558
44	.136 364	.159 091	.181 818	.204 545	.227 273
45	.133 333	.155 556	.177 778	.200 000	.222 222
46	.130 435	.152 174	.173 913	.195 652	.217 391
47	.127 660	.148 936	.170 213	.191 489	.212 766
48	.125 000	.145 833	.166 667	.187 500	.208 333
49	.122 449	.142 857	.163 265	.183 673	.204 082
50	.120 000	.140 000	.160 000	.180 000	.200 000
51	.117 647	.137 255	.156 863	.176 471	.196 078
52	.115 385	.134 615	.153 846	.173 077	.192 308
53	.113 208	.132 075	.150 943	.169 811	.188 679
54	.111 111	.129 630	.148 148	.166 667	.185 185
55	.109 091	.127 273	.145 455	.163 636	.181 818
56	.107 143	.125 000	.142 857	.160 714	.178 571
57	.105 263	.122 807	.140 351	.157 895	.175 439
58	.103 448	.120 690	.137 931	.155 172	.172 414
59	.101 695	.118 644	.135 593	.152 542	.169 492

CHART V , page 3 .

x	1/x	2/x	3/x	4/x	5/x
60	.016 667	.033 333	.050 000	.066 667	.083 333
61	.016 393	.032 787	.049 180	.065 574	.081 967
62	.016 129	.032 258	.048 387	.064 516	.080 645
63	.015 873	.031 746	.047 619	.063 492	.079 365
64	.015 625	.031 250	.046 875	.062 500	.078 125
65	.015 385	.030 769	.046 154	.061 538	.076 923
66	.015 152	.030 303	.045 455	.060 606	.075 758
67	.014 925	.029 851	.044 776	.059 701	.074 627
68	.014 706	.029 412	.044 118	.058 824	.073 529
69	.014 493	.028 986	.043 478	.057 971	.072 464
70	.014 286	.028 571	.042 857	.057 143	.071 429
71	.014 085	.028 169	.042 254	.056 338	.070 423
72	.013 889	.027 778	.041 667	.055 556	.069 444
73	.013 699	.027 397	.041 096	.054 795	.068 493
74	.013 514	.027 027	.040 541	.054 054	.067 568
75	.013 333	.026 667	.040 000	.053 333	.066 667
76	.013 158	.026 316	.039 474	.052 632	.065 789
77	.012 987	.025 974	.038 961	.051 948	.064 935
78	.012 820	.025 641	.038 462	.051 282	.064 103
79	.012 658	.025 316	.037 975	.050 633	.063 291
80	.012 500	.025 000	.037 500	.050 000	.062 500
81	.012 346	.024 691	.037 037	.049 383	.061 728
82	.012 195	.024 390	.036 585	.048 780	.060 976
83	.012 048	.024 096	.036 145	.048 193	.060 241
84	.011 905	.023 810	.035 714	.047 619	.059 524
85	.011 765	.023 529	.035 294	.047 059	.058 823
86	.011 628	.023 256	.034 884	.046 512	.058 140
87	.011 494	.022 989	.034 483	.045 977	.057 471
88	.011 364	.022 727	.034 091	.045 455	.056 818
89	.011 236	.022 472	.033 708	.044 944	.056 180
90	.011 111	.022 222	.033 333	.044 444	.055 556
91	.010 989	.021 978	.032 967	.043 956	.054 945
92	.010 870	.021 739	.032 609	.043 478	.054 348
93	.010 753	.021 505	.032 258	.043 011	.053 763
94	.010 638	.021 277	.031 915	.042 553	.053 191
95	.010 526	.021 053	.031 579	.042 105	.052 632
96	.010 417	.020 833	.031 250	.041 667	.052 083
97	.010 309	.020 619	.030 928	.041 237	.051 546
98	.010 204	.020 408	.030 612	.040 816	.051 020
99	.010 101	.020 202	.030 303	.040 404	.050 505

contin.

CHART V , page 4 .

x	6/x	7/x	8/x	9/x	10/x
60	.100 000	.116 667	.113 333	.150 000	.166 667
61	.098 361	.114 754	.131 148	.147 541	.163 934
62	.096 774	.112 903	.129 032	.145 161	.161 290
63	.095 238	.111 111	.126 984	.142 857	.158 730
64	.093 750	.109 375	.125 000	.140 625	.156 250
65	.092 308	.107 692	.123 077	.138 462	.153 846
66	.090 909	.106 061	.121 212	.136 364	.151 515
67	.089 552	.104 478	.119 403	.134 328	.149 254
68	.088 235	.102 941	.117 647	.132 353	.147 059
69	.086 957	.101 449	.115 942	.130 435	.144 928
70	.085 714	.100 000	.114 286	.128 571	.142 857
71	.084 507	.098 592	.112 676	.126 761	.140 845
72	.083 333	.097 222	.111 111	.125 000	.138 889
73	.082 192	.095 890	.109 589	.123 288	.136 986
74	.081 081	.094 595	.108 108	.121 622	.135 135
75	.080 000	.093 333	.106 667	.120 000	.133 333
76	.078 947	.092 105	.105 263	.118 421	.131 579
77	.077 922	.090 909	.103 896	.116 883	.129 870
78	.076 923	.089 744	.102 564	.115 385	.128 205
79	.075 949	.088 608	.101 266	.113 924	.126 582
80	.075 000	.087 500	.100 000	.112 500	.125 000
81	.074 074	.086 420	.098 765	.111 111	.123 457
82	.073 170	.085 366	.097 561	.109 756	.121 951
83	.072 289	.084 337	.096 386	.108 434	.120 482
84	.071 429	.083 333	.095 238	.107 143	.119 048
85	.070 558	.082 353	.094 118	.105 882	.117 647
86	.069 767	.081 395	.093 023	.104 651	.116 279
87	.068 966	.080 460	.091 954	.103 448	.114 943
88	.068 182	.079 545	.090 909	.102 273	.113 636
89	.067 416	.078 652	.089 888	.101 124	.112 360
90	.066 667	.077 778	.088 889	.100 000	.111 111
91	.065 934	.076 923	.087 912	.098 901	.109 890
92	.065 217	.076 087	.086 957	.097 826	.108 696
93	.064 516	.075 269	.086 022	.096 774	.107 527
94	.063 830	.074 468	.085 106	.095 745	.106 383
95	.063 158	.073 684	.084 211	.094 737	.105 263
96	.062 500	.072 917	.083 333	.093 750	.104 167
97	.061 856	.072 165	.082 474	.092 784	.103 093
98	.061 224	.071 429	.081 633	.091 837	.102 041
99	.060 606	.070 707	.080 808	.090 909	.101 010

CHART V , page 5 .

x	1/x	2/x	3/x	4/x	5/x
100	.010 000	.020 000	.030 000	.040 000	.050 000
101	.009 901	.019 802	.029 703	.039 604	.049 505
102	.009 804	.019 608	.029 412	.039 216	.049 020
103	.009 709	.019 417	.029 126	.038 835	.048 544
104	.009 615	.019 231	.028 846	.038 462	.048 077
105	.009 524	.019 048	.028 571	.038 095	.047 619
106	.009 434	.018 868	.028 302	.037 736	.047 170
107	.009 346	.018 692	.028 037	.037 383	.046 729
108	.009 259	.018 519	.027 778	.037 037	.046 296
109	.009 174	.018 349	.027 523	.036 697	.045 872
110	.009 091	.018 182	.027 273	.036 364	.045 455
111	.009 009	.018 018	.027 027	.036 036	.045 045
112	.008 929	.017 857	.026 786	.035 714	.044 643
113	.008 850	.017 699	.026 549	.035 398	.044 248
114	.008 772	.017 544	.026 316	.035 088	.043 860
115	.008 696	.017 391	.026 087	.034 783	.043 478
116	.008 621	.017 241	.025 862	.034 483	.043 103
117	.008 547	.017 094	.025 641	.034 188	.042 735
118	.008 475	.016 949	.025 424	.033 898	.042 373
119	.008 403	.016 807	.025 210	.033 613	.042 017
120	.008 333	.016 667	.025 000	.033 333	.041 667

CHART V , page 6 .

x	6/x	7/x	8/x	9/x	10/x
100	.060 000	.070 000	.080 000	.090 000	.100 000
101	.059 406	.069 307	.079 208	.089 109	.099 010
102	.058 824	.068 627	.078 431	.088 235	.098 039
103	.058 252	.067 961	.077 670	.087 379	.097 087
104	.057 692	.067 308	.076 923	.086 538	.096 154
105	.057 143	.066 667	.076 190	.085 714	.095 238
106	.056 604	.066 038	.075 472	.084 906	.094 340
107	.056 075	.065 421	.074 766	.084 112	.093 458
108	.055 556	.064 815	.074 074	.083 333	.092 593
109	.055 046	.064 220	.073 394	.082 569	.091 743
110	.054 545	.063 636	.072 727	.081 818	.090 909
111	.054 054	.063 063	.072 072	.081 081	.090 090
112	.053 571	.062 500	.071 429	.080 357	.089 286
113	.053 097	.061 947	.070 796	.079 646	.088 496
114	.052 632	.061 404	.070 175	.078 947	.087 719
115	.052 174	.060 870	.069 565	.078 261	.086 957
116	.051 724	.060 345	.068 966	.077 586	.086 207
117	.051 282	.059 829	.068 376	.076 923	.085 470
118	.050 847	.059 322	.067 797	.076 271	.084 746
119	.050 420	.058 824	.067 227	.075 630	.084 034
120	.050 000	.058 333	.066 667	.075 000	.083 333

LIST OF STANDARD WINDING MACHINES WITH
GEAR FORMULAE

This list contains the catalogue numbers of some of the machines made by the Geo. Stevens Mfg. Co., together with the formula for the determination of gear ratios.

Rack Driven Machines

Model 125	Progressive Universal Winding Machine (rear gear box only)	$r = t/95.49$
Model 130	Space Winder	$r = t/95.49$
Model 131	Resistor Strip Winding Machine	$r = t/95.49$
Model 135	Space Winder	$r = t/31.83$

Cam Driven Machines (using 180° cams)

Model 16	Heavy Duty Winding Machine	$r = T/50$
Model 38-AM	High Speed, Fine Wire Winder	$r = T/50$
Model 39	Miniature Coil Winding Machine	$r = T/50$
Model 115	Standard Bobbin Winder	$r = T/50$
Model 118	Variable Pitch Winding Machine (single layer)	$r = T/50$
Model 125-VP	Variable Pitch Progressive Universal Winding Machine (rear gear box only)	$r = T/50$

Traverse Screw Driven Machines

Model 37-S Multiple Paper Section Winder

$$r = t/150$$

Model 112 Bobbin Winder

$$r = t/200$$

Model 117-A Bobbin Winder

$$r = t/150$$

Universal Winding Machines

Model 120* Universal Winder

$$r = 2/n (1 \pm 1.25\delta/qc)$$

$$q = 2i_1, \text{ where } n/2 = i_1/i_2$$

is written in its lowest terms

$$n = 2d/3c, \text{ for } 78^\circ$$

*(Also Models 125 and 121)

Progressive Universal Winding Machines

Model 125 Progressive Universal Winder

$$r = 2/n [1 \pm (e + 1.25\delta/qc)]$$

$$e = p/n c$$

$$p = Z_r/95.49Z_n$$

$$p = 1/t$$

Equations

$$T = c/\delta; c = T \times \delta; \delta = c/T$$

$$t = 1/\delta; \delta = 1/t$$

$$T = t \times c; t = T/c$$

$$r = z_x Z_n / z_y Z_r$$

INDEX

Arbor	24, 25, 26, 28, 35
Armature Winding	33
Automatic Brake	21, 22
Automatic Counter	22, 23, 24
Automatic Machine, semi—	20
Bibliography	89
Bifilar Universal	66
Bobbin	25, 26, 35
Bobbin Winding	29, 30, 31, 32, 33
Button Wire Guide	49, 50
Cam Driven Machine	6, 29, 36, 37
Cam Follower	10, 12, 46
Cam, linear	10, 11, 45, 46
Cam, milling of—	9, 10, 11, 45
Cam, step cam	60, 61
Cam, variable pitch	11
Cam, 180°	10, 45, 46
Cam, 360°	11
Capacitor Winding	33, 34
Capstan	18, 19
Chuck	2, 24, 27
Collet	6, 7, 24, 27
Counter, dial type	22
Counter, predetermined type	22, 23
Crossover per Turn	68, 69
Crossover per Winding Cycle	68, 69
Degreasing of Wire	54
Diameter of Wire, measurement of—	5, 37
Disc Winding	52, 53
Distributed Capacitance, control of—	67, 68
Dropped Turns, cause of—	50
Flyback Transformer, winding of—	52, 53
Gear Ratio, definition of—	1
Gears, selecting procedure of—	76, 78
Geometry, progressive universal	81, 82, 83
Geometry, universal	68
Guide Pressure	50, 51
Guide, wire guide, types of—	49
Heart Shaped Cam	10, 45, 46
Honeycomb Winding	66, 67

Idler Gears, mounting of—	2, 3
Idler Gears, ratio of—	2
Inherent Pitch	4
Inherent Ratio	32, 33
Litz Wire	54
Marking Knives	42
Multiple Arbor	28
Needle Wire Guide	49, 50, 64
Paper Sections	38, 39, 40, 41, 42
Patterns, progressive universal	83, 84, 85
Patterns, universal, surface	75
Patterns, universal, wall	73
Perfect Lay Coils	35
Production Setup, example of—	56, 64
Progressive Layering	72
Progressive Universal Winding	79
Progressive Winding	14, 15
Rack Driven Machine	1, 2
Ratio of Gears, universal	76
Ratio of Gears, progressive universal	84
Ratio of Gears, cam driven	8
Ratio of Gears, rack driven	4
Ratio of Gears, screw fed	32, 33
Retrogressive Layering	72
Resistor Strip	15
Sine Wave Cam	11
Speed, limitations of—	20, 54, 55
Spinner	19
Square Lay Coils	35
Square Wire Packing	35
Stranded Wires	54
Stripped Insulation, cause of—	50
Tailstock	26
Tap Knotting	55, 56
Triangular Wire Packing	35
Turns Counter	22
Universal Gear Box	47, 48
Variable Pitch Winding, progressive universal	87
Variable Pitch Winding, single layer	6
Winding Cycle	68, 69
Wire Guide Adjustment, progressive universal	51, 81
Wire Guide Adjustment, universal	49, 50, 51

ERRATA *

Page 60, sixth line from top:
to read, Section 6
instead, Section 5

Appendix, Chart II, page 1, Gear Chart for
Screw Traverse Machines, text on top
to read:

Internal machine ratio 20:1; Pitch of
traverse screw 10; $r = t/200$,
 $t =$ turns per inch; for close wound
coils $t = 1/\delta$

text at bottom to read:

D'r = Driver Gear; D'n = Driven
Gear; Id. = Idler Ratio. Idler gear
assemblies may consist of the follow-
ing gears:

$1/2 = 40/80$, or $30/60$;

$1/1 = 60/60$;

$2/1 = 80/40$, or $60/30$.

Appendix, Chart V, page 1, Table of
Reciprocals, ninth line from bottom,
left hand side:

to read,

x	1/x
51	.019 608

instead

x	1/x
51	.091 608

* (Coil Winding, Geo. Stevens Mfg. Co.
1st edition)